

Service
Service
Service



Service Manual

TABLE OF CONTENTS

	Page
Location of PC Boards	1-2
Versions Variation	1-2
Specifications	1-3
Measurement Setup	1-4
Service Aids	1-5
ESD & Safety Instruction	1-6
Lead-free & Service Information	1-7
Connection & Preparation	1-8 to 1-12
Troubleshooting	1-13
Setting Procedure & Repair Instructions	2
Disassembly Instructions & Service positions	3
Block & Wiring Diagram	4
Control Board	5
Main Board	6
Tuner Board	7
Power Board	8
DVD Loader	9
Mechanical Exploded View & Parts List	10
Revision List	11



© Copyright 2006 Philips Consumer Electronics B.V. Eindhoven, The Netherlands
All rights reserved. No part of this publication may be reproduced, stored in a retrieval system or transmitted, in any form or by any means, electronic, mechanical, photocopying, or otherwise without the prior permission of Philips.

Published by SL-ET 0634 Service Audio Printed in The Netherlands Subject to modification.



GB 3141 785 31021

Version 1.1



PHILIPS

LOCATION OF PC BOARDS

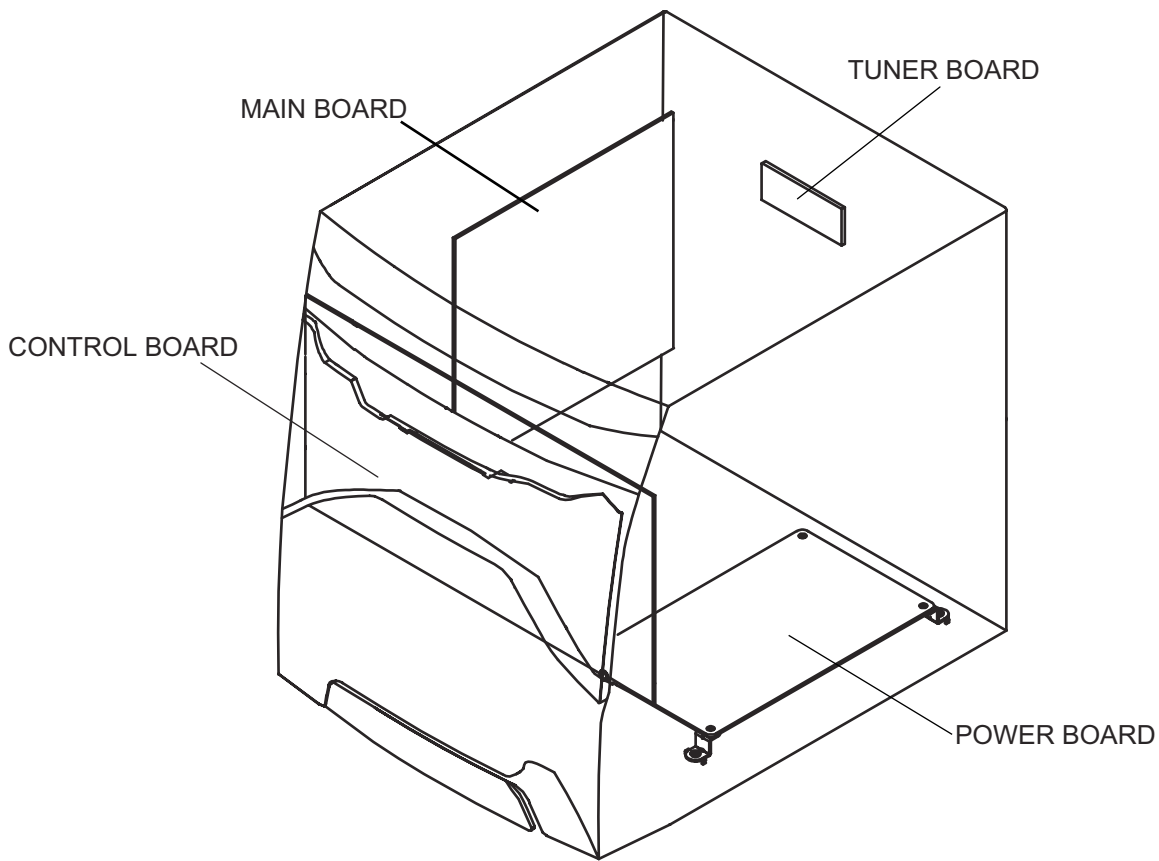

VERSION VARIATIONS:

Type /Versions:	FWD182				
	/98	/55	/51	/68	/79
Features & Board in used:					
Karaoke	x	x	x	x	x
RDS					
Rotary Encoder (volume control)	x	x	x	x	x
Jog Shuttle	x	x	x	x	x
Voltage Selector	x	x			
Aux Input	x	x	x	x	x
Digital Output	x	x	x	x	x
Headphone Socket	x	x	x	x	x
Line Output	x	x	x	x	x
Standby - FTD Clock Display	x	x	x	x	x
Tuner board - ECO6 System	x	x	x	x	x

SPECIFICATIONS

AMPLIFIER SECTION

Output power	1200 W PMPO
Stereo mode	30 W + 30 W RMS
Frequency Response	150 Hz - 18 kHz / ± 3 dB
Signal-to-Noise Ratio	> 60dB (A-weighted)
Input Sensitivity	
AUX/TV In	500 mV
Output Sensitivity	
Headphone	1000 mV ± 2 dB
Line Out	450 mV – 550 mV

TUNER SECTION

Tuning Range	FM 87.5 – 108 MHz (50 kHz steps)
.....	MW 531 – 1602 kHz (9 kHz steps)
.....	MW 530 – 1710 kHz (10 kHz steps)
26 dB Quieting Sensitivity	FM 20 dB
26 dB Quieting Sensitivity	MW 3162 mV/m
Image Rejection Radio	FM 25dB
.....	MW 28 dB
IF Rejection Ratio	FM 60 dB
.....	MW 24 dB
Signal-to-Noise Ratio	FM ≥ 55 dB
.....	MW ≥ 35 dB
MW Suppression Ratio	FM 30 dB
Harmonic Distortion	FM Mono 3 %
.....	FM Stereo 3 %
.....	MW 5 %
Frequency Response	
.....	FM 180 Hz – 10 kHz / ± 6 dB
Stereo Separation	FM 26 dB (1 kHz)
Stereo Threshold	FM 23.5 dB

TAPE SECTION

Frequency Response	
Normal tape (type 1)	80 – 12500 Hz (8 dB)
Signal-to-Noise Ratio	
Normal tape (type 1)	≥ 45 dBA
Wow and flutter	$\leq 0.3\%$ DIN

DVD SECTION

Laser Type	Semiconductor
Disc Diameter	12cm / 8cm
Video Decoding	MPEG-2 / MPEG-1
Video DAC	10 Bits
Signal System	PAL / NTSC
Video Format	4:3 / 16:9
Video S/N	56 dB (minimum)
Composite Video Output	1.0 Vp-p, 75 Ω
S-Video Output	Y - 1.0 Vp-p, 75 Ω
.....	C - 0.286 Vp-p, 75 Ω
Audio DAC	24 Bits / 96 kHz
Frequency Response	4 Hz - 20 kHz (44.1kHz)
.....	4 Hz - 22 kHz (48kHz)
.....	4 Hz - 44 kHz (96kHz)

Digital Output	
.....	SPDIF (Sony Philips digital interface) Coaxial
PCM	IEC 60958
Dolby Digital/DTS	IEC 60958, IEC 61937

MAIN UNIT

Power Supply Rating	110 - 127 / 220 - 240 V
.....	50/60HZ Switchable
Power Consumption	
Active	50 W
ECO Power Standby	<10 W
Dimensions (W x H x D)	265 x 310 x 335 (mm)
Weight	3.9 kg

SPEAKERS

Front speakers	
System	3-way, Bass reflex
Impedance	4 Ω
Speaker drivers	16.5cm woofer,
.....	5cm tweeter
Frequency response	50 Hz – 20 kHz
Dimensions (W x H x D)	
.....	190 x 310 x 207 (mm)
Weight	4.8 kg/each

Specifications and external appearance are subject to change without notice.

MEASUREMENT SETUP

Tuner FM

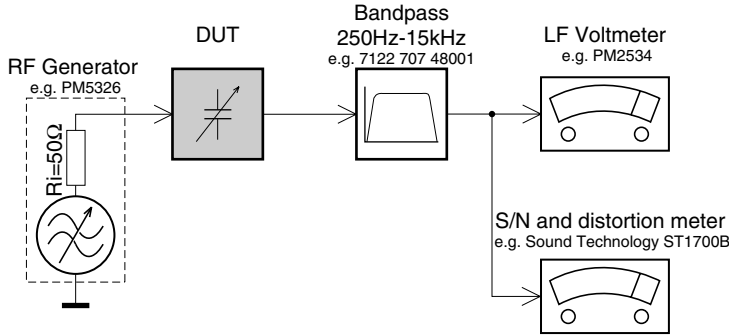

Use a bandpass filter to eliminate hum (50Hz, 100Hz) and disturbance from the pilotone (19kHz, 38kHz).

Tuner AM (MW,LW)

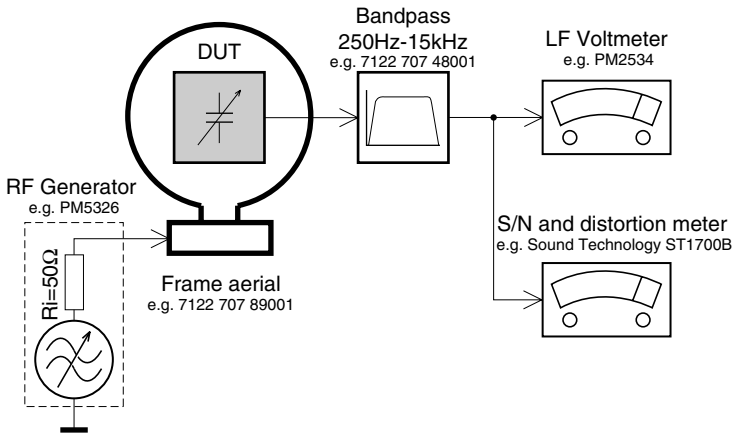

To avoid atmospheric interference all AM-measurements have to be carried out in a Faraday's cage. Use a bandpass filter (or at least a high pass filter with 250Hz) to eliminate hum (50Hz, 100Hz).

CD

Use Audio Signal Disc SBC429 4822 397 30184 (replaces test disc 3)

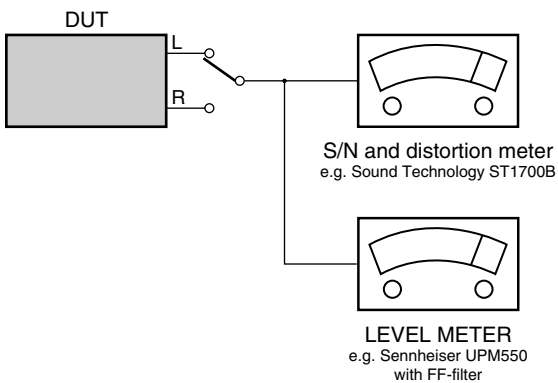

Recorder

Use Universal Test Cassette **CrO2** SBC419 4822 397 30069 or Universal Test Cassette **Fe** SBC420 4822 397 30071

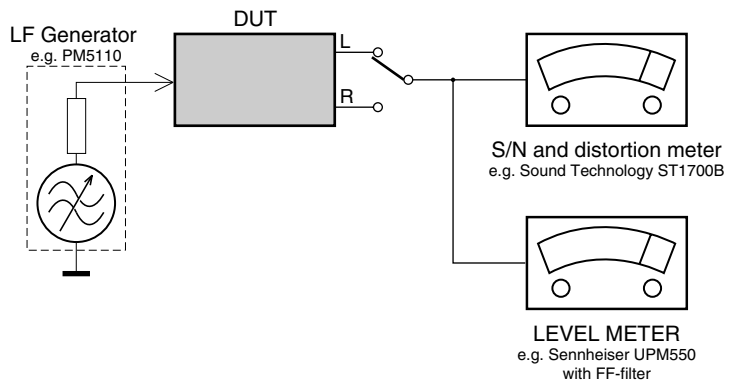

SERVICE AIDS

Service Tools:

Universal Torx driver holder	4822 395 91019
Torx bit T10 150mm	4822 395 50456
Torx driver set T6-T20	4822 395 50145
Torx driver T10 extended	4822 395 50423

Compact Disc:

SBC426/426A Test disc 5 + 5A	4822 397 30096
SBC442 Audio Burn-in test disc 1kHz	4822 397 30155
SBC429 Audio Signals disc	4822 397 30184
Dolby Pro-logic Test Disc	4822 395 10216

ESD Equipment:

Anti-static table mat - large 1200x650x1.25mm ...	4822 466 10953
anti-static table mat - small 600x650x1.25mm	4822 466 10958
Anti-static wristband	4822 395 10223
Connectorbox (1M Ω)	4822 395 11307
Extension cable (to connect wristband to conn.box)	4822 320 11305
Connecting cable (to connect table mat to conn.box)	4822 320 11306
Earth cable (to Connect product to mat or box) --	4822 320 11308
Complete kit ESD3 (combining all above products)	4822 320 10671
Wristband tester	4822 344 13999

HANDLING CHIP COMPONENTS

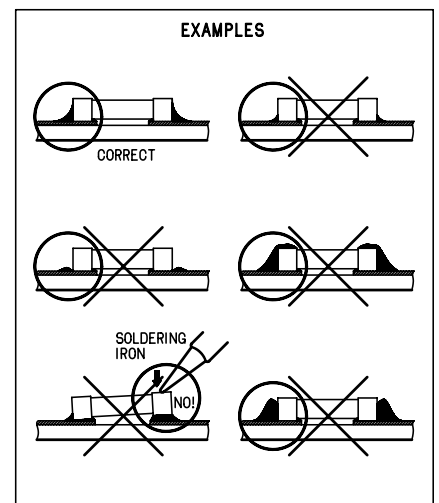
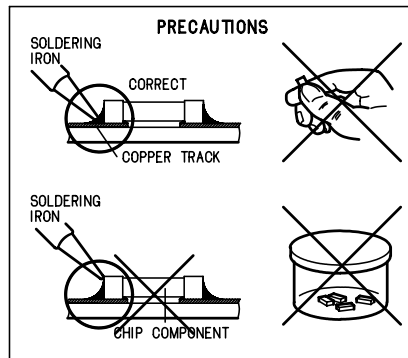
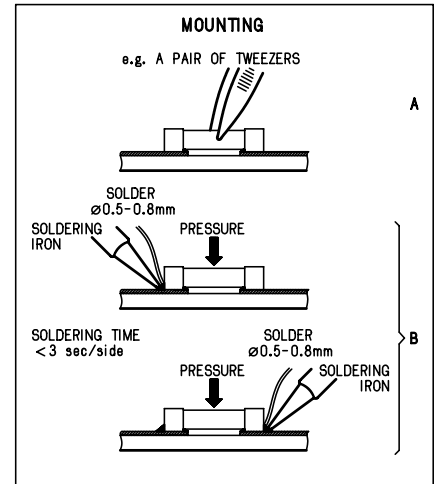
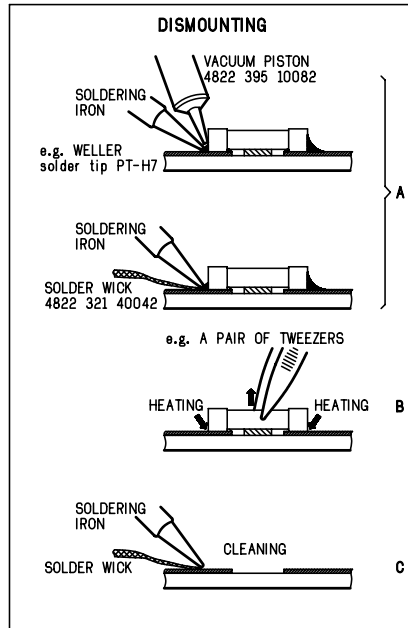
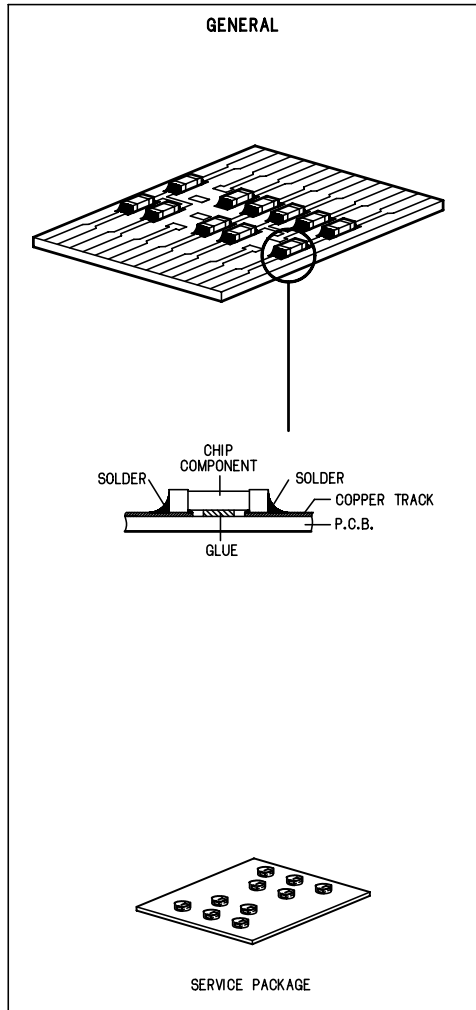

(GB) WARNING

All ICs and many other semi-conductors are susceptible to electrostatic discharges (ESD). Careless handling during repair can reduce life drastically.

When repairing, make sure that you are connected with the same potential as the mass of the set via a wrist wrap with resistance.

Keep components and tools also at this potential.

ESD**(NL) WAARSCHUWING**

Alle IC's en vele andere halfgeleiders zijn gevoelig voor electrostatische ontladingen (ESD).

Onzorgvuldig behandelen tijdens reparatie kan de levensduur drastisch doen verminderen. Zorg ervoor dat u tijdens reparatie via een polsband met weerstand verbonden bent met hetzelfde potentiaal als de massa van het apparaat.

Houd componenten en hulpmiddelen ook op hetzelfde potentiaal.

(F) ATTENTION

Tous les IC et beaucoup d'autres semi-conducteurs sont sensibles aux décharges statiques (ESD).

Leur longévité pourrait être considérablement écourtée par le fait qu'aucune précaution n'est prise à leur manipulation.

Lors de réparations, s'assurer de bien être relié au même potentiel que la masse de l'appareil et enfilez le bracelet serti d'une résistance de sécurité.

Veiller à ce que les composants ainsi que les outils que l'on utilise soient également à ce potentiel.

(D) WARNUNG

Alle ICs und viele andere Halbleiter sind empfindlich gegenüber elektrostatischen Entladungen (ESD).

Unvorsichtige Behandlung im Reparaturfall kann die Lebensdauer drastisch reduzieren.

Veranlassen Sie, dass Sie im Reparaturfall über ein Pulsarmband mit Widerstand verbunden sind mit dem gleichen Potential wie die Masse des Gerätes.

Bauteile und Hilfsmittel auch auf dieses gleiche Potential halten.

(I) AVVERTIMENTO

Tutti IC e parecchi semi-conduttori sono sensibili alle scariche statiche (ESD).

La loro longevità potrebbe essere fortemente ridotta in caso di non osservazione della più grande cauzione alla loro manipolazione.

Durante le riparazioni occorre quindi essere collegato allo stesso potenziale che quello della massa dell'apparecchio tramite un braccialetto a resistenza.

Assicurarsi che i componenti e anche gli utensili con quali si lavora siano anche a questo potenziale.

(GB)

Safety regulations require that the set be restored to its original condition and that parts which are identical with those specified, be used.

"Pour votre sécurité, ces documents doivent être utilisés par des spécialistes agréés, seuls habilités à réparer votre appareil en panne".

(NL)

Veiligheidsbepalingen vereisen, dat het apparaat bij reparatie in zijn oorspronkelijke toestand wordt teruggebracht en dat onderdelen, identiek aan de gespecificeerde, worden toegepast.

(F)

Les normes de sécurité exigent que l'appareil soit remis à l'état d'origine et que soient utilisées les pièces de rechange identiques à celles spécifiées.

(D)

Bei jeder Reparatur sind die geltenden Sicherheitsvorschriften zu beachten. Der Originalzustand des Geräts darf nicht verändert werden; für Reparaturen sind Original-Ersatzteile zu verwenden.

(I)

Le norme di sicurezza esigono che l'apparecchio venga rimesso nelle condizioni originali e che siano utilizzati i pezzi di ricambio identici a quelli specificati.

"After servicing and before returning set to customer perform a leakage current measurement test from all exposed metal parts to earth ground to assure no shock hazard exist. The leakage current must not exceed 0.5mA."

**(GB) Warning !**

Invisible laser radiation when open.
Avoid direct exposure to beam.

(S) Varning !

Osynlig laserstrålning när apparaten är öppnad och spärren är urkopplad. Betrakta ej strålen.

(SF) Varoitus !

Avatussa laitteessa ja suojalukituksen ohitettaessa olet alttiina näkymättömälle laserisäteilylle. Älä katso säteeseen!

(DK) Advarse !

Usynlig laserstråling ved åbning når sikkerhedsafbrydere er ude af funktion. Undgå udsættelse for stråling.

INFORMATION ABOUT LEAD-FREE SOLDERING

Philips CE is producing lead-free sets from 1.1.2005 onwards.

IDENTIFICATION:

Regardless of special logo (not always indicated) one must treat all sets from 1 Jan 2005 onwards, according next rules:



Example S/N:

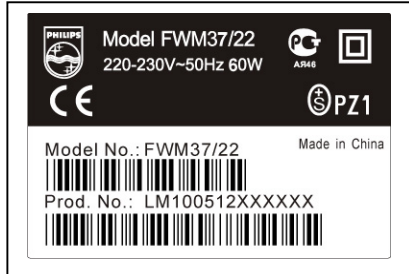

Bottom line of typeplate gives a 14-digit S/N. Digit 5&6 is the year, digit 7&8 is the week number, so in this case 2005 wk12

So from 0501 onwards = from 1 Jan 2005 onwards

Important note: In fact also products of year 2004 must be treated in this way as long as you avoid mixing solder-alloys (leaded/ lead-free). So best to always use SAC305 and the higher temperatures belong to this.

Due to lead-free technology some rules have to be respected by the workshop during a repair:

- Use only lead-free solder alloy Philips SAC305 with order code 0622 149 00106. If lead-free solder-paste is required, please contact the manufacturer of your solder-equipment. In general use of solder-paste within workshops should be avoided because paste is not easy to store and to handle.
- Use only adequate solder tools applicable for lead-free solder alloy. The solder tool must be able
 - To reach at least a solder-temperature of 400°C,
 - To stabilize the adjusted temperature at the solder-tip
 - To exchange solder-tips for different applications.
- Adjust your solder tool so that a temperature around 360°C – 380°C is reached and stabilized at the solder joint. Heating-time of the solder-joint should not exceed ~ 4 sec. Avoid temperatures above 400°C otherwise wear-out of tips will rise drastically and flux-fluid will be destroyed. To avoid wear-out of tips switch off un-used equipment, or reduce heat.
- Mix of lead-free solder alloy / parts with leaded solder alloy / parts is possible but PHILIPS recommends strongly to avoid mixed solder alloy types (leaded and lead-free).
If one cannot avoid or does not know whether product is lead-free, clean carefully the solder-joint from old solder alloy and re-solder with new solder alloy (SAC305).
- Use only original spare-parts listed in the Service-Manuals. Not listed standard-material (commodities) has to be purchased at external companies.
- Special information for BGA-ICs:
 - always use the 12nc-recognizable soldering temperature profile of the specific BGA (for de-soldering always use the lead-free temperature profile, in case of doubt)
 - lead free BGA-ICs will be delivered in so-called 'dry-packaging' (sealed pack including a silica gel pack) to protect the IC against moisture. After opening, dependent of MSL-level seen on indicator-label in the bag, the BGA-IC possibly still has to be baked dry. (MSL=Moisture Sensitivity Level). This will be communicated via AYS-website.
 - Do not re-use BGAs at all.
- For sets produced before 1.1.2005 (except products of 2004), containing leaded solder-alloy and components, all needed spare-parts will be available till the end of the service-period. For repair of such sets nothing changes.
- On our website www.atyourservice.ce.Philips.com you find more information to:
 - * BGA-de-/soldering (+ baking instructions)
 - * Heating-profiles of BGAs and other ICs used in Philips-sets

You will find this and more technical information within the "magazine", chapter "workshop news".

For additional questions please contact your local repair-helpdesk.

SERVICE INSTRUCTION

Safety regulations require that after a repair, the set must be returned in its original condition. Pay in particular attention to the following points:

- Route the wire trees correctly and fix them with the mounted cable clamps.
- Check the insulation of the AC Power lead for external damage.
- Check the strain relief of the AC Power cord for proper function.
- Check the electrical DC resistance between the AC Power Plug and the secondary side (only for sets which have a AC Power isolated power supply):
 1. Unplug the AC Power cord and connect a wire between the two pins of the AC Power plug.
 2. Set the AC Power switch to the "on" position (keep the AC Power cord unplugged!).
 3. Measure the resistance value between the pins of the AC Power plug and the metal shielding of the tuner or the aerial connection on the set. The reading should be larger than 4.5 Mohm (For U.S. it should be between 4.2 Mohm and 12 Mohm).
 4. Switch "off" the set, and remove the wire between the two pins of the AC Power plug.
- Check the cabinet for defects, to avoid touching of any inner parts by the customer.

Connections

Step 1: Placing speakers and subwoofer

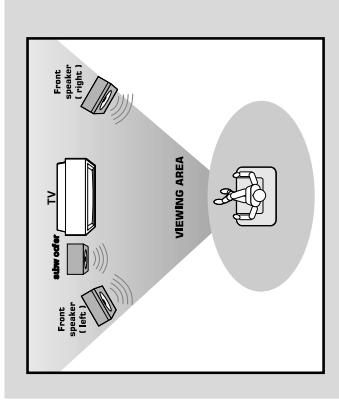

Place the front left and right speakers at equal distances from the TV set and at an angle of approximately 45 degrees from the listening position.

Notes:

- To avoid magnetic interference, do not position the front speakers too close to your TV set.
- Allow adequate ventilation around the DVD Mini Hi-Fi System.

Step 2: Connecting speakers and subwoofer

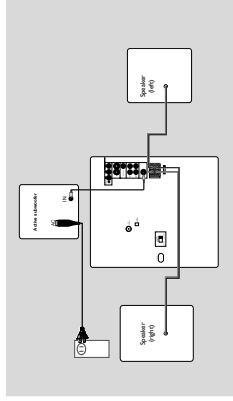

Connect the speaker wires to the SPEAKERS (FRONT) terminals, right speaker to "R" and left speaker to "L", coloured (marked) wire to "+" and black (unmarked) wire to "-". Fully insert the stripped portion of the speaker wire into the terminal as shown.

Connect the subwoofer using subwoofer cable to the SUBWOOFER OUT jack on the DVD Mini Hi-Fi System to active input jack.

Notes:

- For optimal sound performance, use the supplied speakers.
- Do not connect more than one speaker to any one pair of +/- speaker terminals.
- Subwoofer must be active subwoofer.
- Do not connect speakers with an impedance lower than the speakers supplied. Please refer to the SPECIFICATIONS section of this manual.

Speakers	⊖	⊕
Front Left (L)	Black	White
Front Right (R)	Black	Red

IMPORTANT!

The type plate is located on the rear of the system.

To avoid overheating of the system, a safety circuit has been built in. Therefore, your system may switch to Standby mode automatically under extreme conditions. If this happens, let the system cool down before reusing it.

Connections

Step 3: Connecting TV set

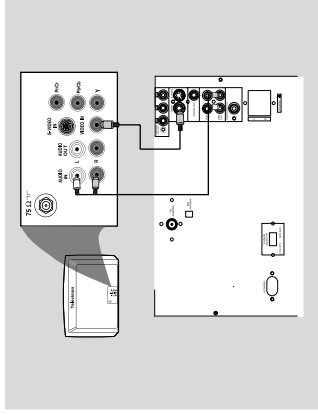

IMPORTANT!

- You only need to make one video connection from the following options, according to the capabilities of your TV system.
 - S-Video or Component Video connection provides higher picture quality. These options must be available on your TV set.
 - Connect the system directly to the TV set.

Using Video In jack (CVBS)

Use the composite video cable (yellow) to connect the system's VIDEO jack to the video input jack (or labeled as AV In, Video In, Composite or Baseband) on the TV set.

Using LINE OUT jack (L/R)

To listen this system channels through TV, use the audio cables (white/red) to connect LINE OUT (L/R) jacks to the corresponding AUDIO IN jacks on the TV set.

Using component Video In jack (Pr PbY)

Use the component video cables (red/blue/green) to connect the system's Pr PbY jacks to the corresponding Component video input jacks (or labeled as Pr, Pb, Y or YUV) on the TV set.

To listen this system channels through TV, use the audio cables (white/red) to connect LINE OUT (L/R) jacks to the corresponding AUDIO IN jacks on the TV set.

Connections

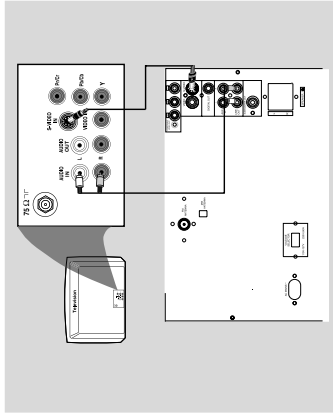

Using S-Video In jack

Use the S-Video cable (not supplied) to connect the system's **S-VIDEO** jack to the S-Video input jack (or labeled as Y/C or S-VHS) on the TV set.

To listen this system channels through TV, use the audio cables (white/red) to connect **LINE OUT (L/R)** jacks to the corresponding **AUDIO IN** jacks on the TV set.

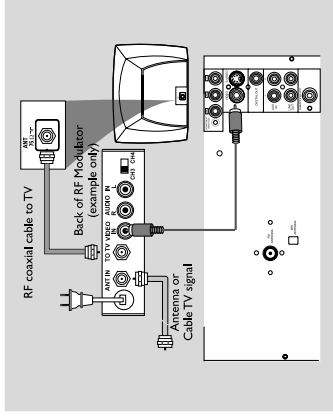

Using an accessory RF modulator

Use the composite cable (yellow) to connect the system's **VIDEO** jack to the video input jack on the RF modulator.

Use the RF coaxial cable (not supplied) to connect the RF modulator to your TV's RF jack.

IMPORTANT!

- If your TV set only has a single Antenna In jack (or labeled as 75 ohm or RF In), you will need a RF modulator in order to view the DVD playback via TV. See your electronics retailer or contact Philips for details on RF modulator availability and operations.

Connections

Step 4: Connecting FM/MW antennas

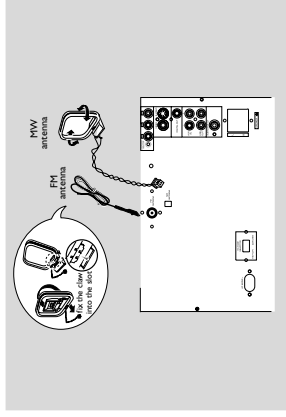

Connect the supplied MW loop antenna to the **MW** jack. Place the MW loop antenna on a shelf or attach it to a stand or wall.

Connect the supplied FM antenna to the **FM** jack. Extend the FM antenna and fix its end to the wall.

For better FM stereo reception, connect an outdoor FM antenna to the **FM ANTENNA**

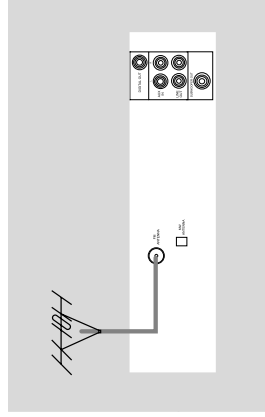

Notes:

- Adjust the position of the antennas for optimal reception.
- Position the antennas as far as possible from your TV set, VCR or other radiation sources to prevent unwanted interference.

Step 5: Connecting the power cord

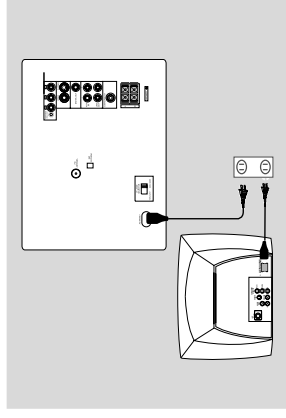

After everything is connected properly, plug in the AC power cord to the power outlet.

Never make or change any connection with the power switched on.

On the DVD Mini Hi-Fi System

"AUTO TUNING TRACK PRESET PLAY" may appear on the display panel. Press **▶/II** on the front panel to search and store all available radio stations or press **■** to exit.

If your system is equipped with a Voltage Selector, set the **VOLTAGE SELECTOR** to the local power line voltage.



Connections

Step 6: Connecting a VCR or cable/satellite box

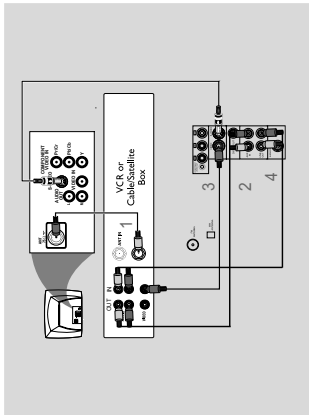

Viewing and listening to playback

- 1 Connect the VCR or Cable/Satellite Box to the TV system as shown.
- 2 Connect the system's **AUX IN** jacks to the AUDIO OUT jacks on the VCR or Cable/Satellite box.

Before starting operation, press **AUX** on the remote control to select "AUX" in order to activate the input source.

Using the VCR for recording DVDs

Some DVDs are copy-protected. You cannot record or dub protected discs using a VCR.

- 1 Connect the system's **VIDEO** jack to the VIDEO IN jack on the VCR.
- 2 Connect the system's **LINE OUT (R/L)** jacks to the AUDIO IN jacks on the VCR. This will allow you to make analog stereo (two channel, right and left) recording.

To view DVD playback while recording

You must connect the system to your TV system using the S-VIDEO (as shown above) or the Component (Pr-Pb-Y) video connection.

Step 7: Connecting digital audio equipment

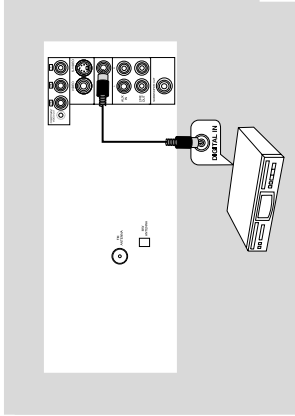

Recording(digital)

Connect the system's DIGITAL OUT jack to the DIGITAL IN jack on a digital recording device.

Before operation, set the DIGITAL OUTPUT according to the audio connection.

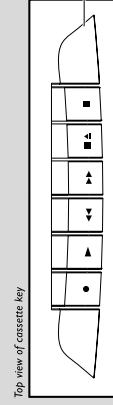
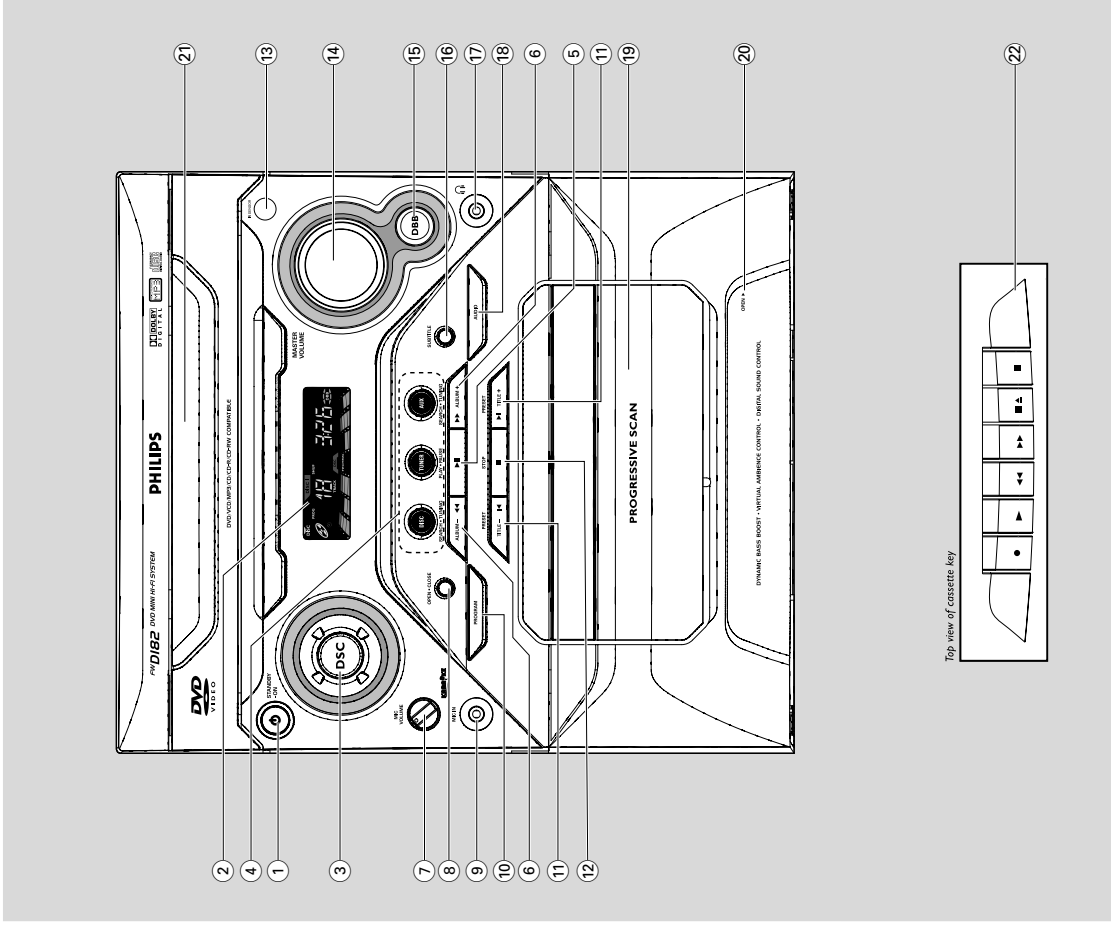

Functional Overview

- in Disc mode, press to fast reverse/forward the disc.
- ⑥ **◀/▶**
 - in Disc mode, press to skip to the previous/next chapter/track.
 - in Tuner mode, to select a preset radio station number
- ⑦ **PLAY/PAUSE ▶||**
 - to start or interrupt disc playback.
 - to resume playback from last stop point.
- ⑧ **STOP ■**
 - to stop playing the disc.
- ⑨ **REPEAT A-B**
 - to repeat a specific section on a disc.
- ⑩ **REPEAT**
 - to select variations of continuous playback.
- ⑪ **SUBTITLE**
 - to select desired subtitle.
- ⑫ **AUDIO**
 - to select the audio channel.
- ⑬ **SLEEP**
 - to set the sleep timer function.
- ⑭ **ANGLE**
 - to select the angles cyclically.
- ⑮ **DIM**
 - to select different brightness for VFD.
- ⑯ **DSC**
 - to select various sound effect.
- ⑰ **POWER ⏻**
 - to switch to standby mode.
- ⑱ **Numeric Keypad (0-9)**
 - to enter a track/title number of the disc.
 - to enter a number of preset radio stations.
- ⑲ **VOL +/-**
 - adjust the volume level.
 - adjust key control/ ECHO level in karaoke mode.
- adjust speakers level in speaker setting mode.
- ⑳ **OK**
 - to exit or confirm the selection.
- ㉑ **GOTO**
 - to go direct to desired title, chapter or time.
- ㉒ **PROGRAM**
 - in disc mode, to program favorite tracks.
 - in tuner mode, to program favorite stations.
- ㉓ **SHUFFLE**
 - to playback in random mode.

Remote control

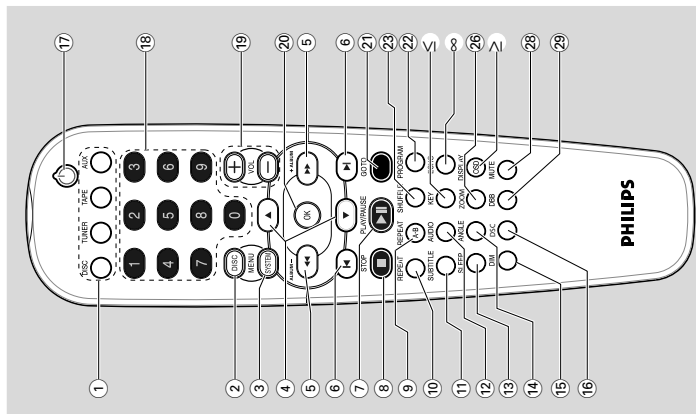

Notes:

- First, select the source you wish to control by pressing one of the source select keys on the remote control (DISC or TUNER, for example).
- Then select the desired function (▶▶, ◀◀ or ▶| for example).
- ① **SOURCE**
 - to select the relevant active mode: DISC, TUNER, TAPE or AUX.
- ② **DISC MENU (disc mode only)**
 - to enter or exit the disc contents menu.
- ③ **SYSTEM MENU (disc mode only)**
 - to enter or exit the system menu bar.
- ④ **▲ / ▼**
 - to select movement direction in disc contents menu/system menu bar.
- ⑤ **◀◀ / ▶▶**
 - to tuner mode, to tune to lower or higher radio frequency. (◀◀ / ▶▶)

Functional Overview

- to change the tone level to suit your vocal range.
- ⑪ **◀ / ▶|**
 - for TUNER.....to program favorite stations.
 - for DISC.....to skip to the previous/next chapter/track.
 - for TUNER.....to select a preset radio station.
- ⑫ **STOP ■**
 - for DISCto stop playback or to clear a programme.
- ⑬ **SENSOR**
 - point the remote control towards this sensor.
- ⑭ **VOLUME**
 - to adjust master volume level.
- ⑮ **DBB**
 - to settings to enhance the bass response.
- **Controls on the system**
 - ① **STANDBY ON**
 - to switch the system on or Standby mode.
 - ② **DISPLAY SCREEN**
 - to view the current status of the system.
 - ③ **DSC**
 - to select various sound effect:
 - ④ **SOURCE**
 - to select disc tray.
 - ⑤ **TUNER**
 - to select waveband(FM/MW).
 - ⑥ **AUX**
 - to select a connected external source: AUX(auxiliary)
 - ⑦ **▶|| (PLAY/PAUSE)**
 - for DISCto start or interrupt playback.
 - for DISCpress to search backward/forward.
 - for TUNER ----- to tune to a lower or higher radio frequency.
 - ⑧ **MICVOL.**
 - to adjust the mixing level for karaoke or microphone recording.
 - ⑨ **OPEN,CLOSE**
 - to open or close the disc tray.
 - ⑩ **MIC IN**
 - to connect microphone jack.
 - ⑪ **PROGRAM**
 - for DISC.....to program favorite tracks.

Preparations

IMPORTANT!

- Make sure to complete the preparation procedures before operating the system.

Step 1: Inserting batteries into the remote control

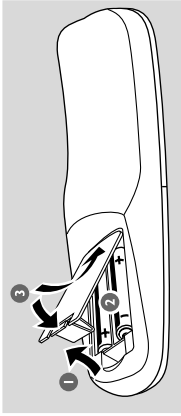

- 1 Open the battery compartment.
- 2 Place two batteries (Type R06 or AA) in the compartment with the correct polarity as indicated by "+" and "-" symbols.
- 3 Close the cover.

Using the remote control to operate the system

- 1 Point the remote control directly at the remote sensor (IR) on the front panel.
- 2 Select the source you wish to control by pressing one of the source select buttons on the remote control (for example TAPE, TUNER).

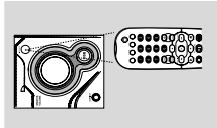

- 3 Then select the desired function (for example ►II◀ or ►▶).

CAUTION!

- Remove batteries if they are exhausted or will not be used for a long time.
- Do not use old and new or different types of batteries in combination.
- Batteries contain chemical substances, so they should be disposed of properly.

Preparations

- 1 In disc mode, stop playback and press **SYSTEM MENU**.

- 2 Select **16** icon and press **▼**.

- 3 Press **◀◀ / ▶▶** / **▲** / **▼** keys on the remote control to toggle through the functions and select your preferred option.

Move to **6** and press **▶▶▶**.
Move to "TV System" and press **▶▶▶**.

AUTO

- Select this if the connected TV set is compatible with both NTSC and PAL (multi system). The output format will be consistent with the video signal of the disc.

NTSC

- Select this if the connected TV set is NTSC system. It will change the video signal of a PAL video disc and output to NTSC system.

PAL

- Select this if the connected TV set is PAL system. It will change the video signal of an NTSC disc and output to PAL format.

- 4 Select an item and press **OK**.

To remove the menu

Press **SYSTEM MENU**.

Step 3: Setting language preference

You can select your preferred language settings so that this DVD Mini Hi-Fi System will automatically switch to the language for you whenever you load a disc. If the language selected is not available on the disc, the language set by default will be used instead. But the menu language of the DVD Mini Hi-Fi System cannot be changed once selected.

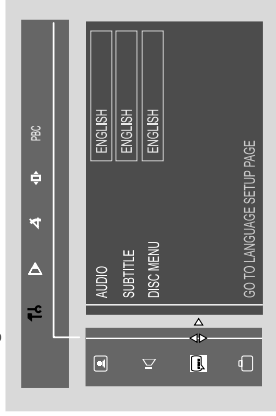

- 1 In disc mode, stop playback and press **SYSTEM MENU**.

- 2 Select **16** icon and press **▼**.

- 3 Press **◀◀ / ▶▶** / **▲** / **▼** keys on the remote control to select your preferred option.

Move to **6** and press **▶▶▶**.

Move to one of the following and press **▶▶▶**.

- Audio (disc's soundtrack)
- Subtitle (disc's subtitles)
- Disc Menu (on screen menu)

- 4 Press **▲** / **▼** to select a language and press **OK**.

- 5 Repeat **steps 3~4** for other settings.

To remove the menu

Press **SYSTEM MENU**.

Step 2: Setting the TV set

IMPORTANT!

- Make sure you have completed all the necessary connections.

- 1 Press **DISC** on the front panel (or press **DISC** on the remote control).

- 2 Turn on the TV set and set to the correct Video-In channel. You should see the blue Philips DVD background screen on the TV set.

You may go to channel 1 on your TV set, then press the channel down button repeatedly until you see the Video In channel.

Or, you can use the TV remote control to select different video modes.

Or, set TV to channel 3 or 4 if you are using an RF modulator.

Selecting the color system that matches your TV set

This DVD Mini Hi-Fi System is compatible with both NTSC and PAL. For the playback of a DVD disc on this DVD Mini Hi-Fi System, the color systems of the DVD, TV set and DVD Mini Hi-Fi System should match.

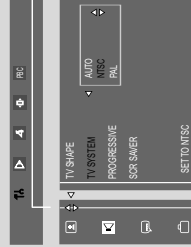
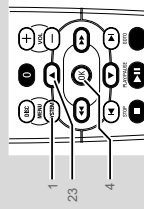
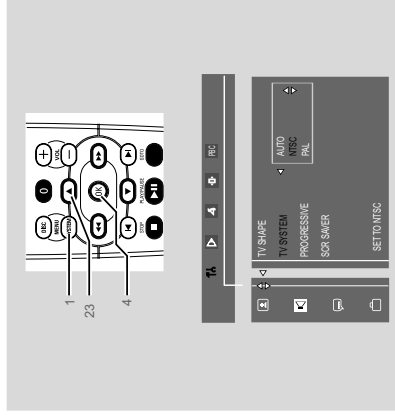

Troubleshooting

WARNING

Under no circumstances should you try to repair the system yourself, as this will invalidate the warranty. Do not open the system as there is a risk of electric shock.

If a fault occurs, first check the points listed below before taking the system for repair. If you are unable to remedy a problem by following these hints, consult your dealer or Philips for help.

Problem	Solution
No power. "UNRECOVERABLE DISC" is displayed.	<ul style="list-style-type: none">Check if the AC power cord is properly connected.Check if the disc is inserted upside down.Wait until the moisture condensed at the lens has cleared.Replace or clean the disc, see "Maintenance".Use a readable disc or correctly recorded format MP3-CD.
No picture.	<ul style="list-style-type: none">Select the appropriate video input mode on the TV set.Check if the TV set is switched on.Check the video connection.Check if the system is securely connected.Sometimes a slight picture distortion may appear. This is not a malfunction.Clean the disc.Connect the system to the S-video input of your TV set.
Distorted or poor picture.	<ul style="list-style-type: none">The aspect ratio is fixed on the DVD disc.The aspect ratio may not be changed for some TV systems.Insert a readable disc.Check the disc type, color system and region code.Clean the disc.Place the disc with the playback side down.Press SYSTEM MENU to turn off the setup menu.Cancel the parental control rating function or change the rating level.Moisture has condensed inside the system.Remove the disc and leave the system turned on for about an hour.Disconnect the power plug from the jack, and insert again.
The aspect ratio of the screen cannot be changed even though you have set the TV shape. The DVD player does not start playback.	
The system does not respond when the buttons are pressed.	

Troubleshooting

Problem	Solution
The language for the sound or subtitle cannot be changed when playing a DVD.	<ul style="list-style-type: none">Multi-language sound or subtitle is not recorded on the DVD.Changing the language for the sound or subtitle is prohibited on the DVD.
No image is output when a function is selected.	<ul style="list-style-type: none">Make sure the component is connected correctly.Press the correct function button for the input source.
Sound cannot be heard or is of poor quality	<ul style="list-style-type: none">Adjust the volume.Disconnect the headphones.Check that the speakers are connected correctly.Check if the stripped speaker wire is clamped.If the system is in pause, slow motion or fast forward/reverse mode, press ► to resume the normal play mode.Make sure the MP3-CD was recorded within 32-256 kbps bit rate with sampling frequencies at 48 kHz, 44.1 kHz or 32 kHz.
Poor radio reception.	<ul style="list-style-type: none">If the signal is too weak, adjust the antenna or connect an external antenna for better reception.Increase the distance between the MINI HiFi System and your TV set or VCR.
Recording or playback cannot be made	<ul style="list-style-type: none">Clean deck parts, see "Maintenance".Use only NORMAL tape.Apply a piece of adhesive tape over the missing tab space.
The tape deck door cannot open	<ul style="list-style-type: none">Remove and reconnect the AC power plug and switch on the system again.
Left and right sound outputs are reversed.	<ul style="list-style-type: none">Check the speaker connections and location.
The remote control does not function.	<ul style="list-style-type: none">Point the remote control at the remote control sensor of the unit.Reduce the distance to the player.Remove any possible obstacles.Replace the batteries with new ones.Check that the batteries are loaded correctly.
The display is dark.	<ul style="list-style-type: none">Press DIM again.

REPAIR INSTRUCTIONS (1 of 2)

MAIN UNIT REPAIR CHART

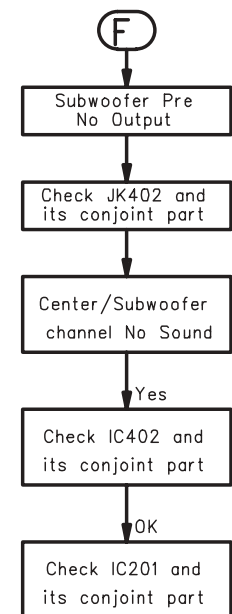
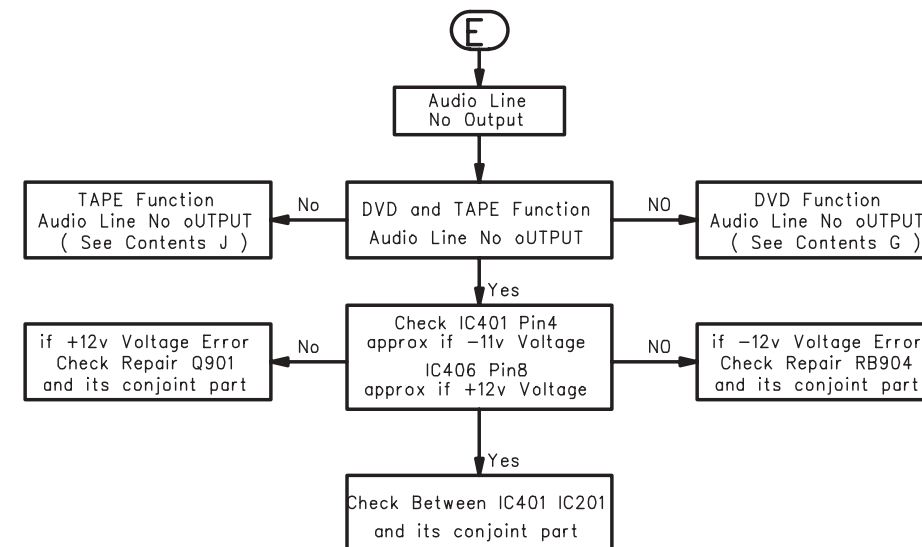
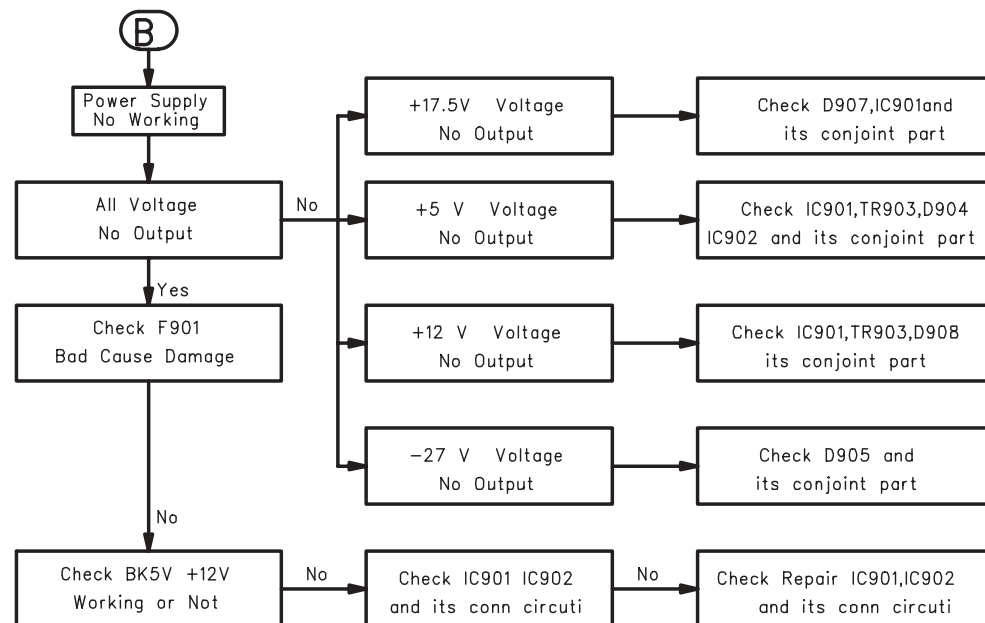
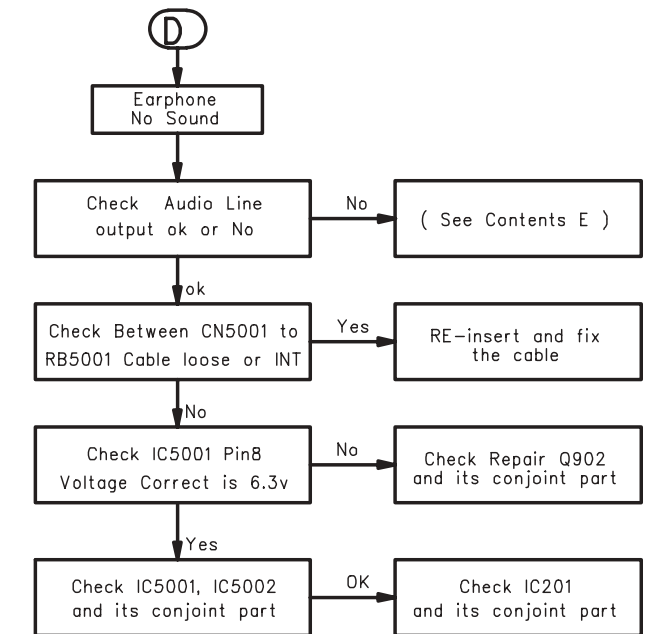
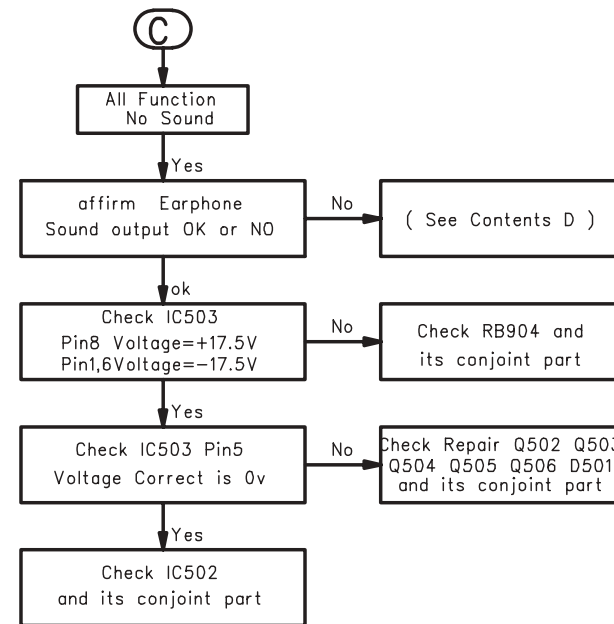
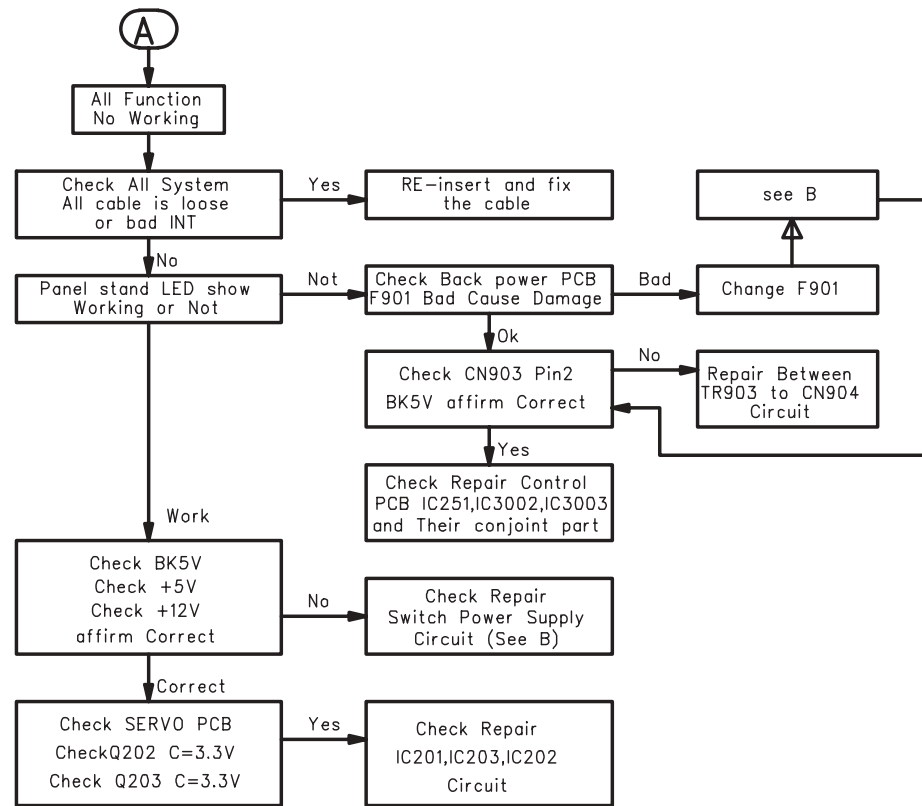
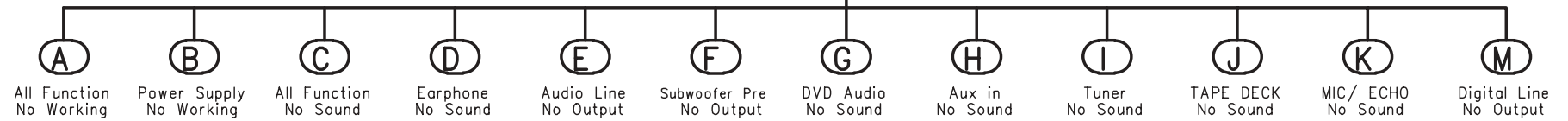

REPAIR INSTRUCTIONS (2 of 2)

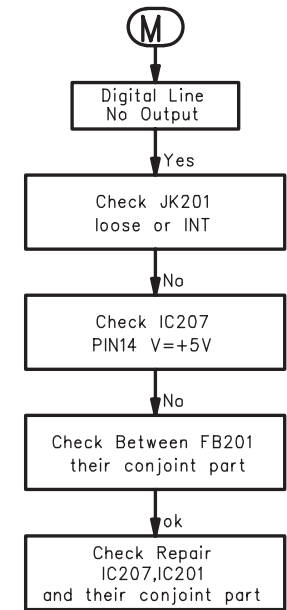
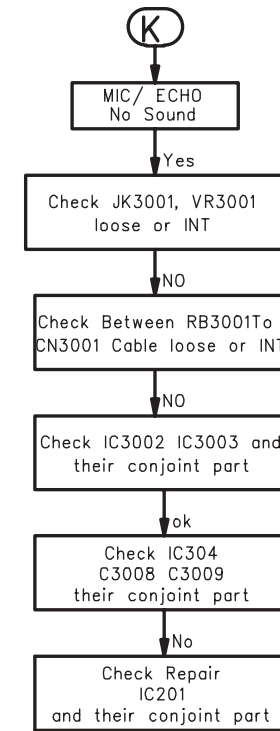
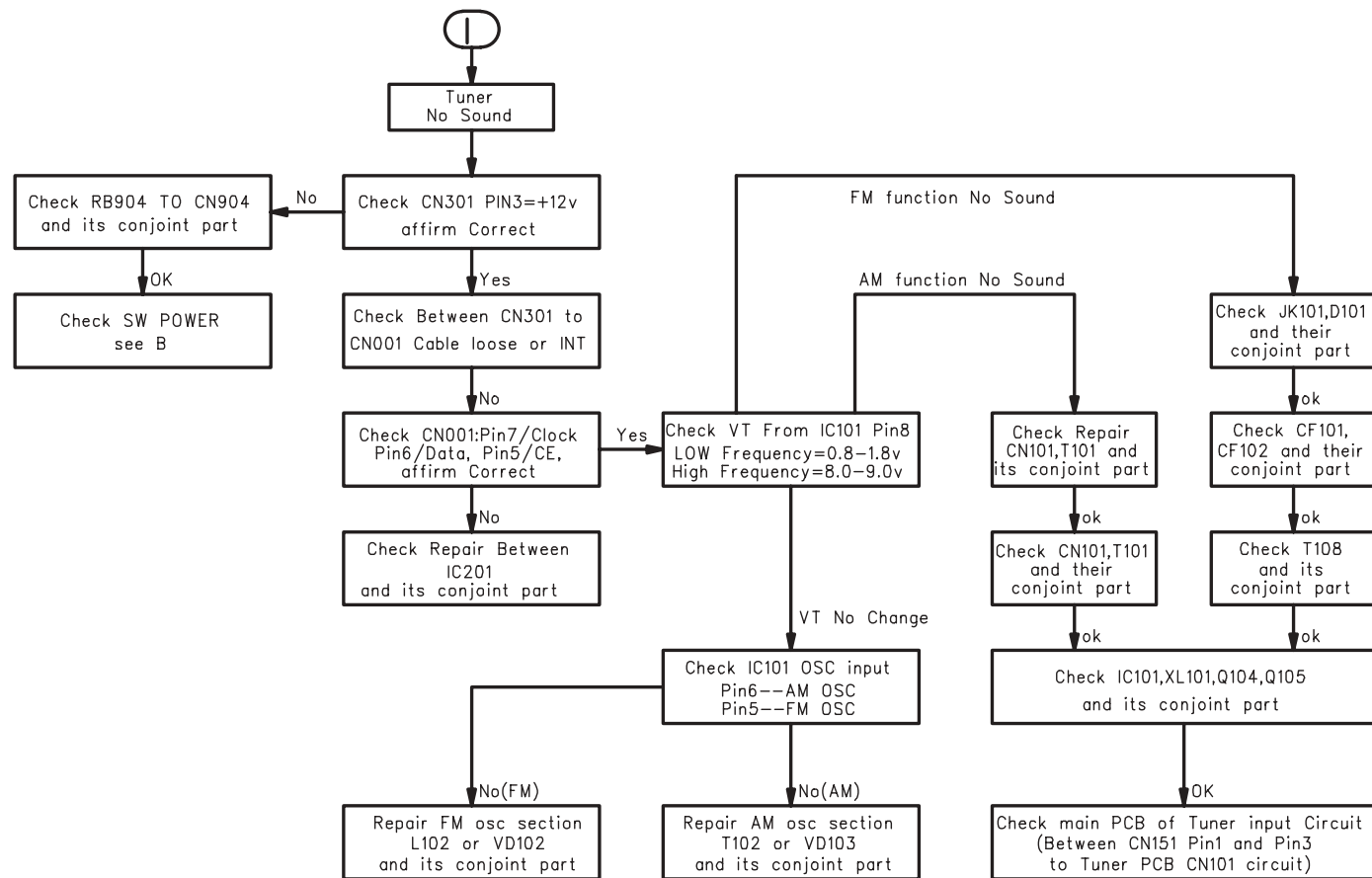
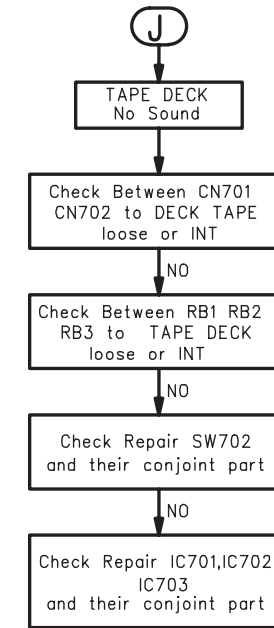
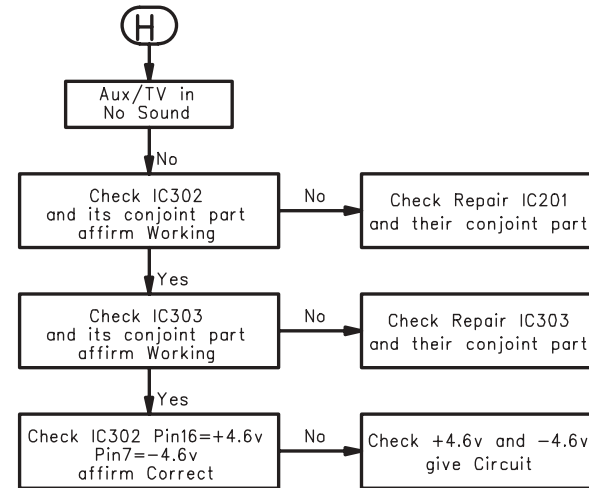
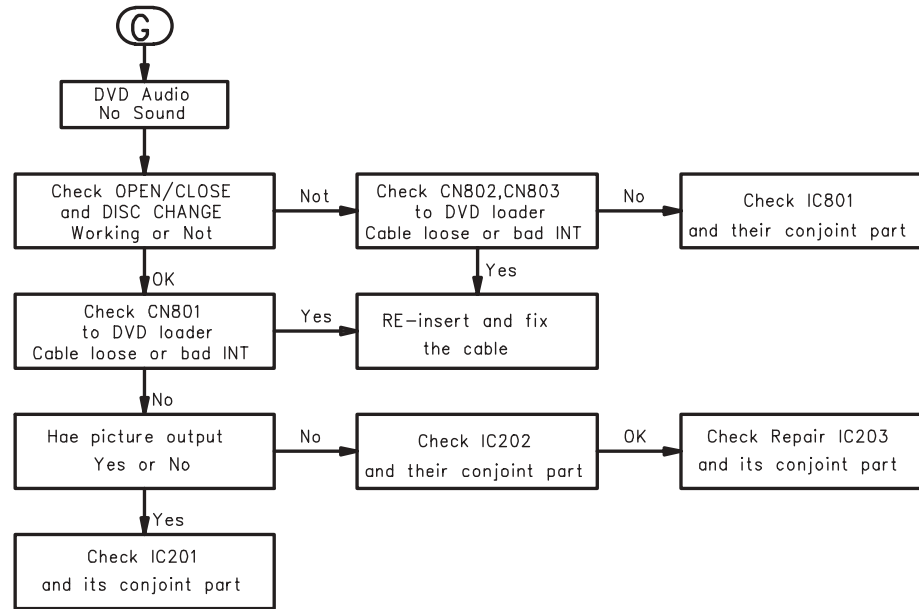

DISMANTLING INSTRUCTIONS

Dismantling the DVD Module

- 1) Loosen the 4 screws at top cover , 2 screws at slide Cover and 4 screws at back panel as Figure 1 & 2.
- 2) Loosen the 4 screws at DVD loader bracket as Figure 3.
- 3) Loosen the 4 screws at DVD loader as Figure 4.

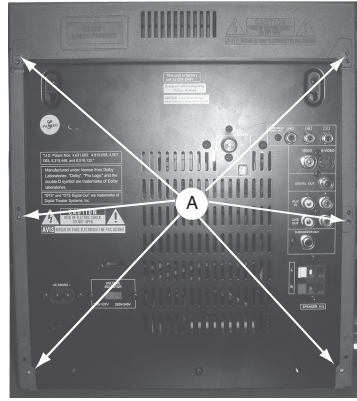

Figure 1

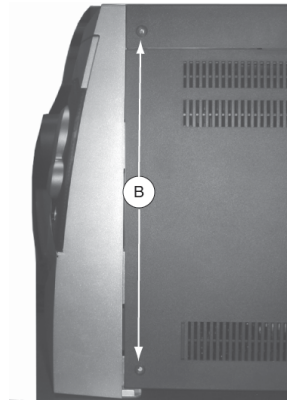

Figure 2

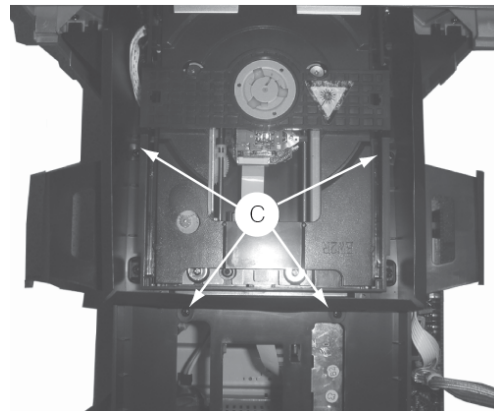

Figure 3

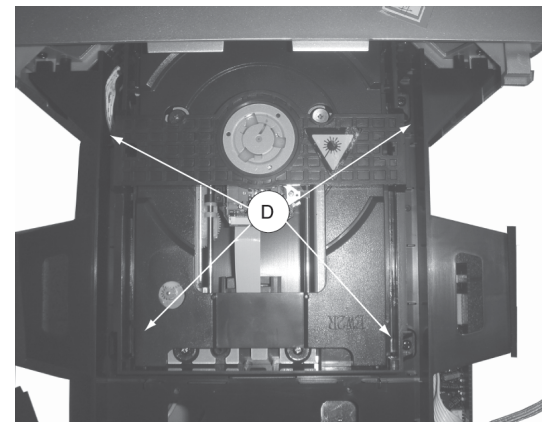

Figure 4

- 4) Push the gear slowly towards the front as shown in figure 5 until the CDC tray starts to move out of the Front Cabinet. The CDC tray is now disengaged and can be pulled out completely.



Figure 5

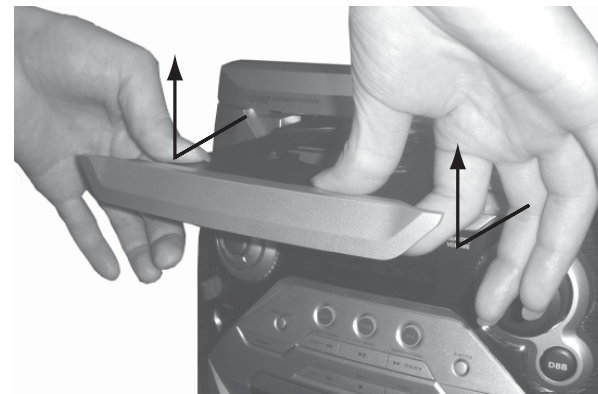

Figure 6

Dismantling of the Cover Front Display

- 1) Remove the Volume knobs & Mic knob as stated in Dismantling the Cover Front Display in Figure 7 & 8.

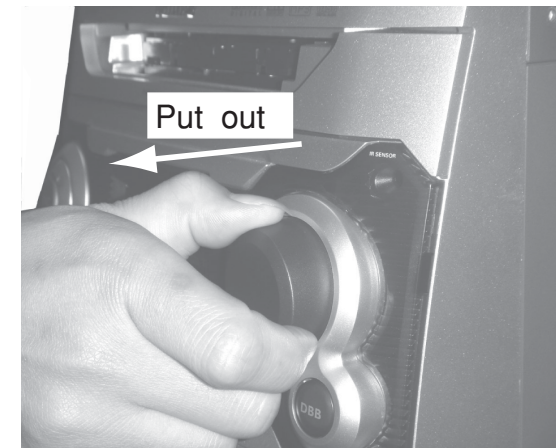

Figure 7

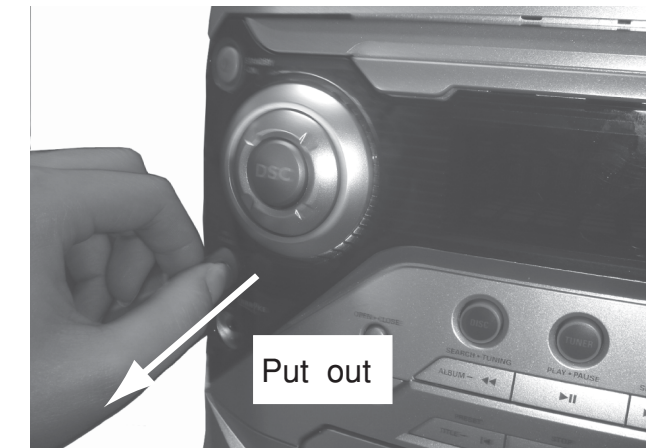

Figure 8

Dismantling the Main board

- 1) Release 7 screws 'E' to free the Main board from the back panel Assembly as shown in Figure 9.
- 2) Loosen 1 screw 'G' at the side of the set as shown in Figure 10.
- 3) Release 2 screws 'F' on bottom of the cover as shown in Figure 11.

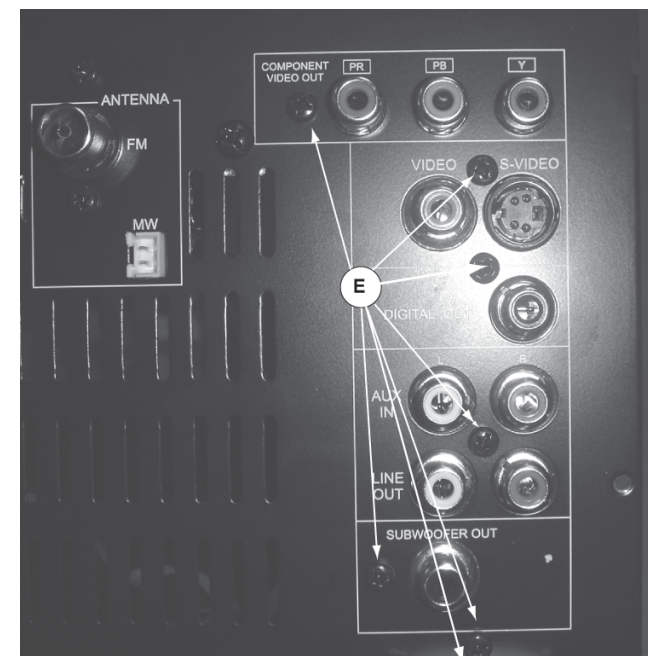

Figure 9

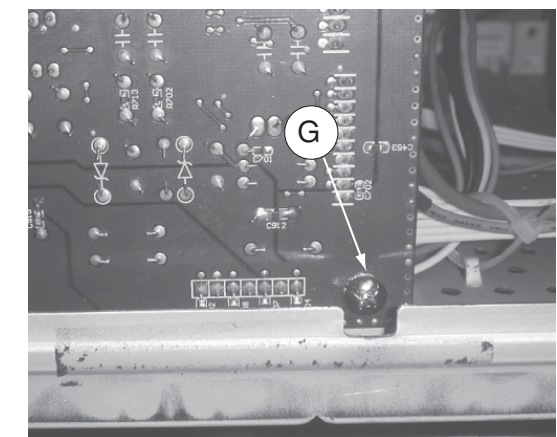

Figure 10

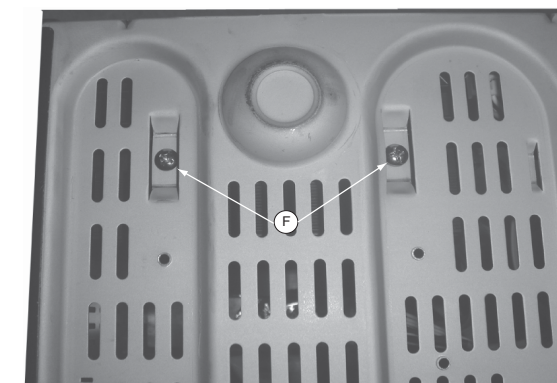

Figure 11

Dismantling of the Key Board and Cassette module

1) Loosen 13 screws 'H' to remove the KEY board figure 12.

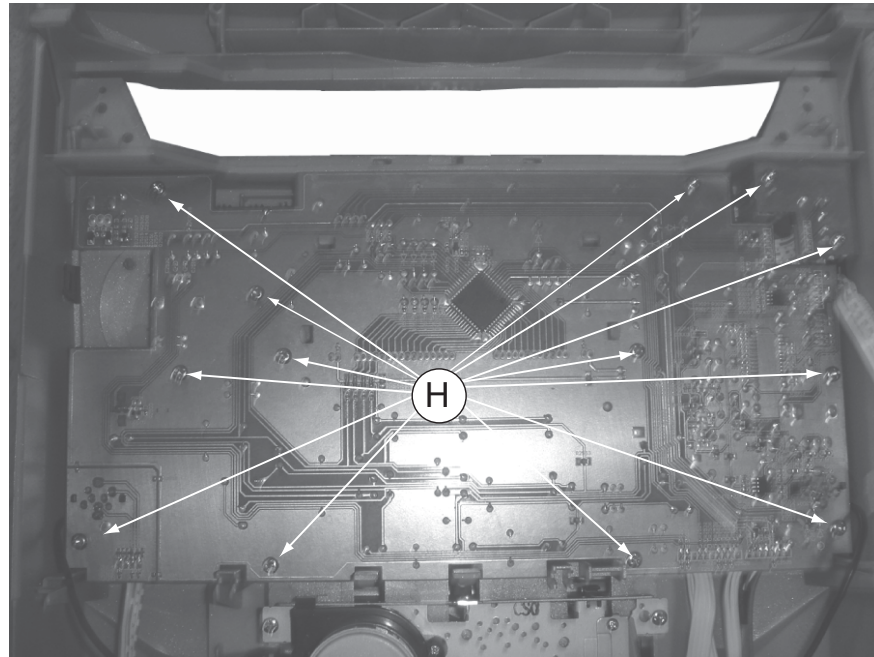

Figure 12

4) Loosen 4 screws 'I' to remove the Cassette Module figure 13.

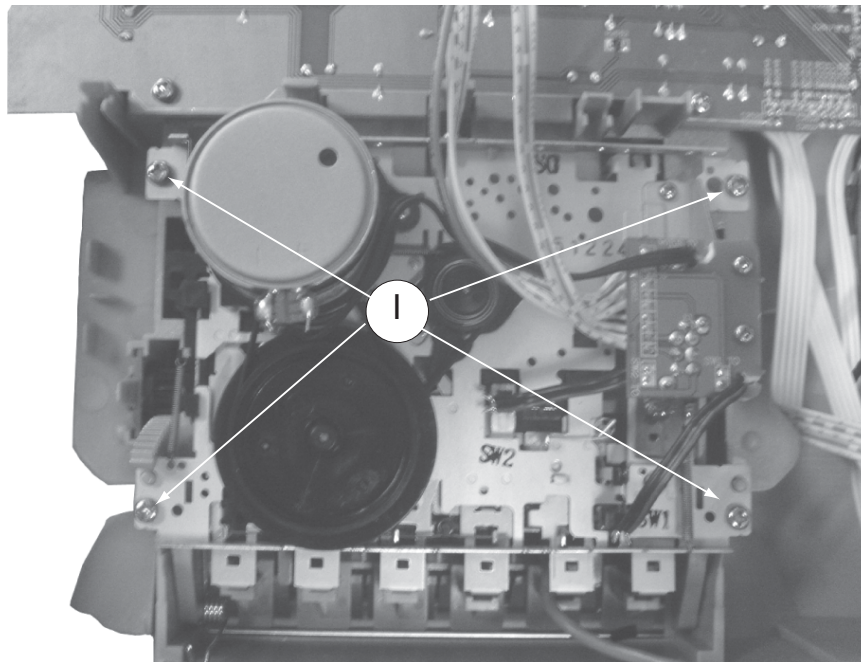

Figure 13

Dismantling of the Power Board

1) Loosen 4 screws 'J' to remove the Power Board figure 14.

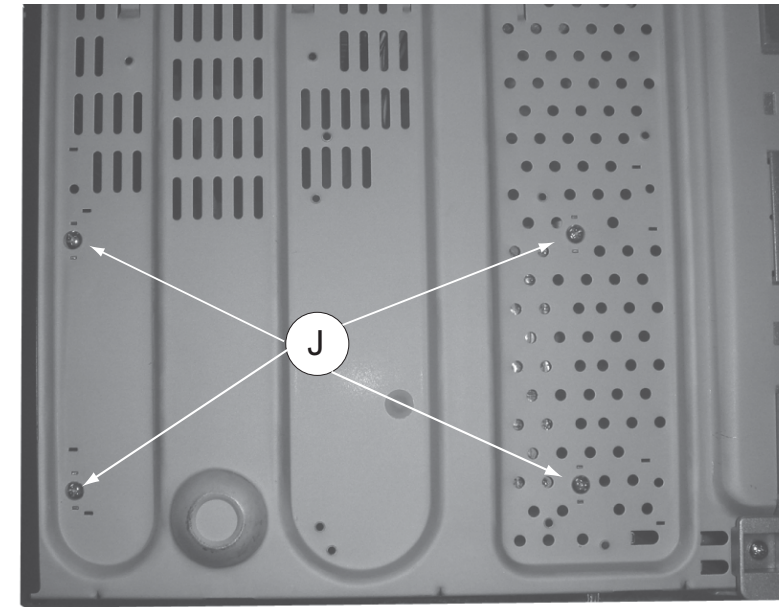

Figure 14

2) Remove the catch 'K' using cutter as shown in figure 15.

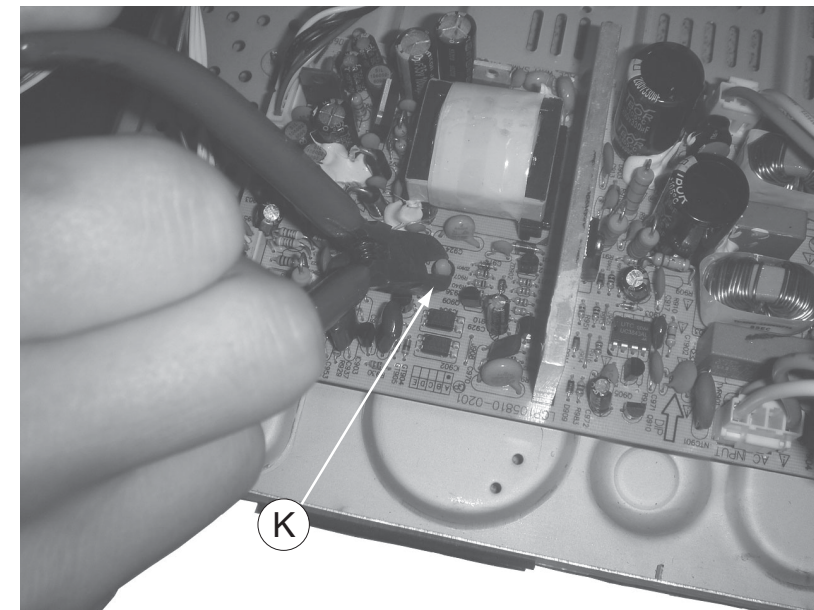

Figure 15

Service positions

Service position A



Service position B

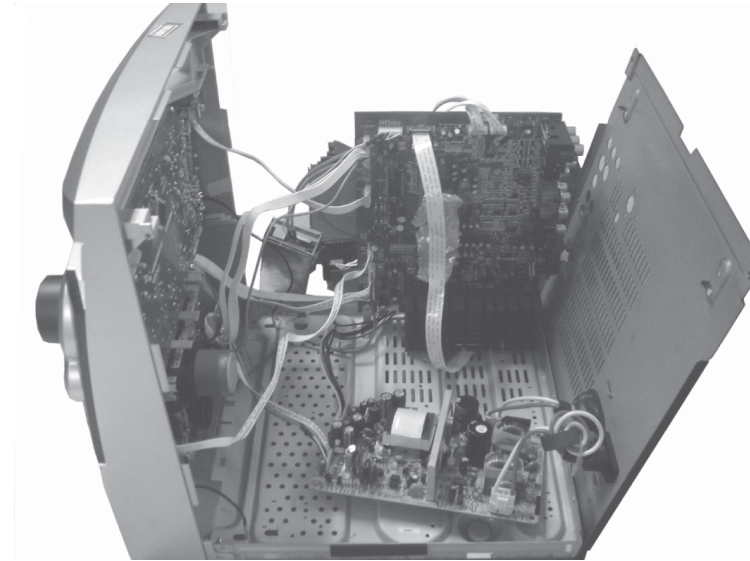

Note: After re-assembly, it is very important to ensure the wires are properly inserted into their respective sockets and routed not to touch or obstruct any moving parts.

Service position C

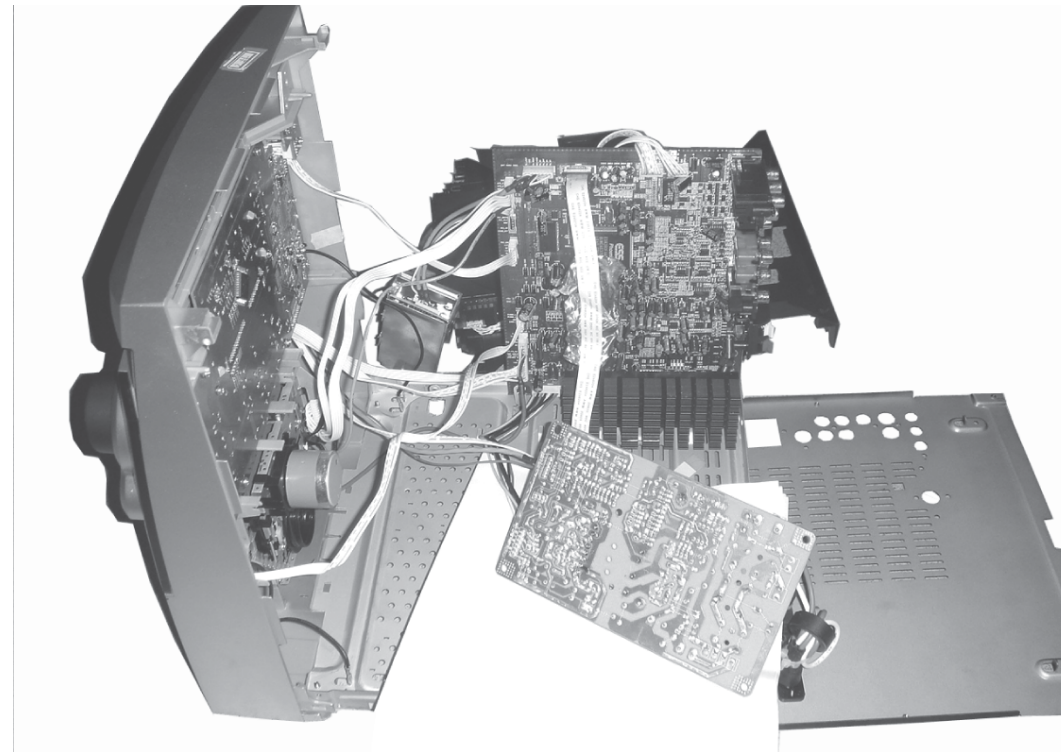

SET BLOCK DIAGRAM

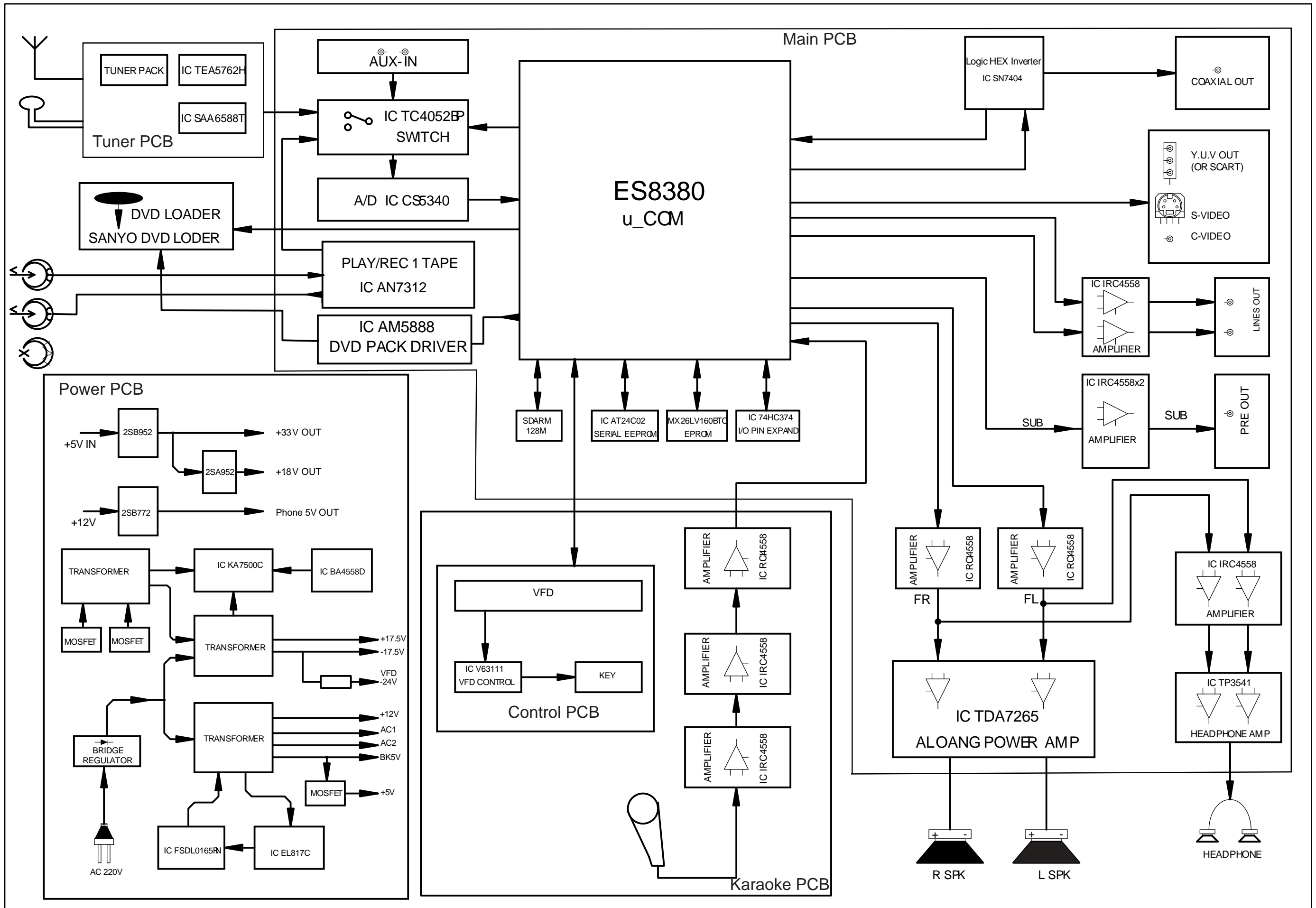

WIRING DIRGRAM

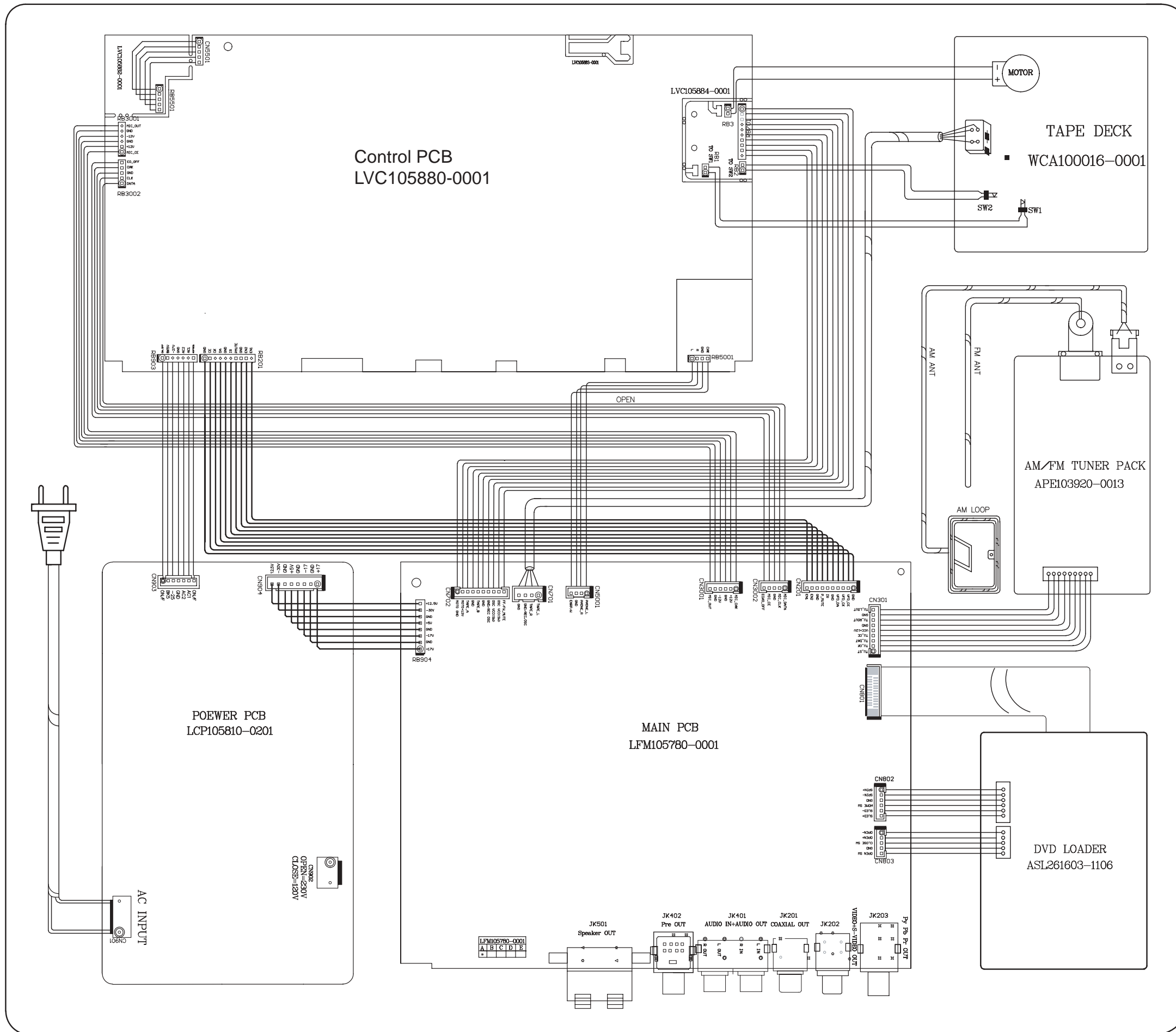

FTD DISPLAY PIN ASSIGNMENT

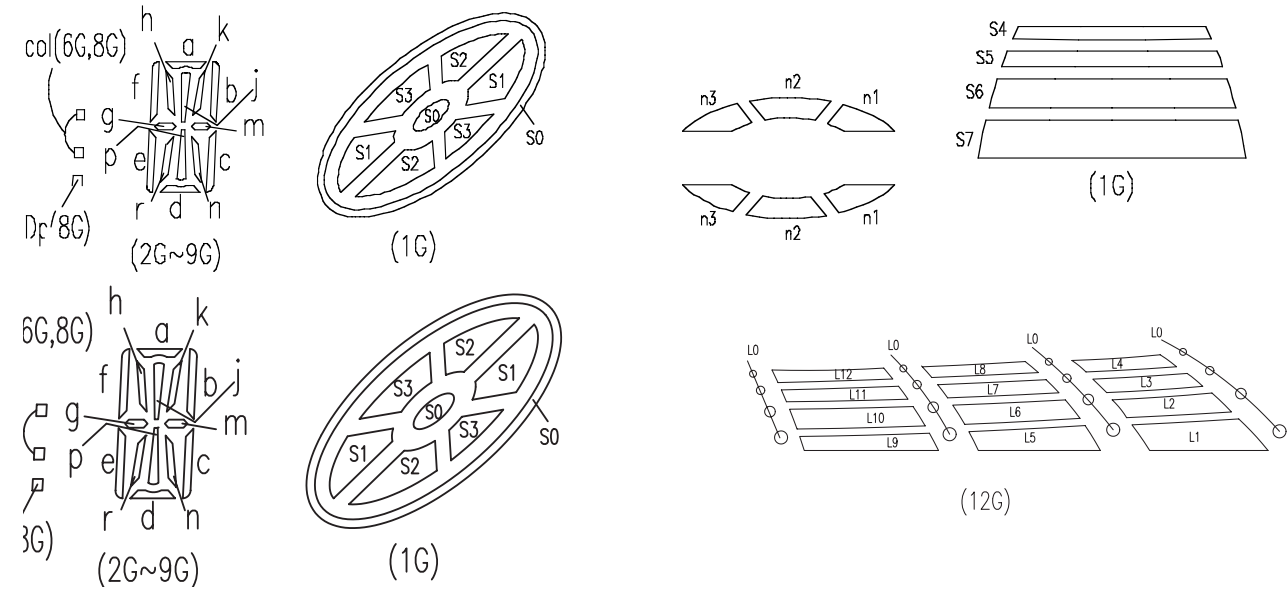
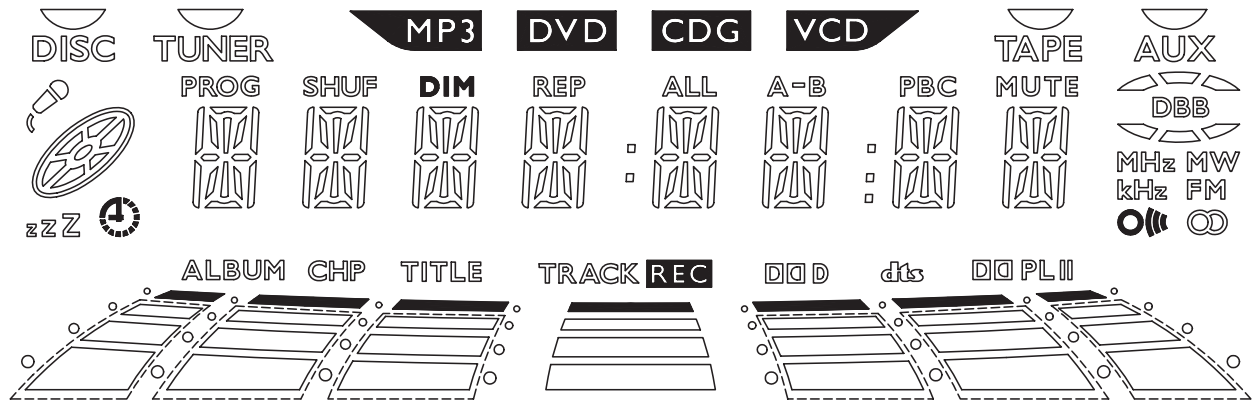

KEY & KARAOKE BOARD

TABLE OF CONTENTS

FTD Display Pin Assignment 5-1
 Pin Connection 5-1
 Circuit Diagram (Key PCB) 5-2
 Circuit Diagram (Karaoke PCB) 5-3
 PCB Layout Top View 5-4
 PCB Layout Bottom View 5-5
 Electrical Parts List & Voltages 5-6

	1G	2G	3G	4G	5G	6G	7G	8G	9G	10G	11G	12G
P1	DISC	TUNER		MP3	DVD	CDG	VCD	Dp	TAPE	AUX	L0	L0
P2						col	A	col		DBB	L1	L1
P3	S1	PROG	SHUF	DIM	REP	ALL	-B	PBC	MUTE	n1	L2	L2
P4	S2	a	a	a	a	a	a	a	a	n2	L3	L3
P5	S3	h	h	h	h	h	h	h	h	n3	L4	L4
P6	S0	j, p	j, p	j, p	j, p	j, p	j, p	j, p	j, p	MW	L5	L5
P7	zzZ	k	k	k	k	k	k	k	k	FM	L6	L6
P8		b	b	b	b	b	b	b	b	MHz	L7	L7
P9	S4	f	f	f	f	f	f	f	f	kHz	L8	L8
P10	S5	m	m	m	m	m	m	m	m		L9	L9
P11	S6	g	g	g	g	g	g	g	g		L10	L10
P12	S7	c	c	c	c	c	c	c	c		L11	L11
P13	REC	e	e	e	e	e	e	e	e		L12	L12
P14	TRACK	r	r	r	r	r	r	r	r		ALBUM	DDD PL II
P15		n	n	n	n	n	n	n	n		CHP	dts
P16		d	d	d	d	d	d	d	d		TITLE	DDD

PIN CONNECTION

PIN NO.	1	2	3	4	5	6	7	8	9	10	11	12	13	14	15	16	17	18	19	20	21
CONNECTION	F	F	NP	NP	12G	11G	10G	9G	8G	7G	6G	5G	4G	3G	2G	1G	NX	NX	NX	NX	NX
PIN NO.	22	23	24	25	26	27	28	29	30	31	32	33	34	35	36	37	38	39	40	41	42
CONNECTION	NX	P1	P2	P3	P4	P5	P6	P7	P8	P9	P10	P11	P12	P13	P14	P15	P16	NP	NP	F	F

Note

1. F : Filament

2. G :Grid

3. P :Anode

4. NP :No Pin

5. Nx :No extended

CIRCUIT DIAGRAM: KEY PCB

C1	C4	C2511	B2	C2523	A2	C2535	B3	D2501	D2	IC251	B2	R2506	C1	R2519	A2	R2532	D1	R2544	A2	RB2	C4	TA2505	A1	XL2501	C2
C2	D4	C2512	A2	C2524	A2	C2536	B3	D2503	A2	JK5001	B4	R2507	C1	R2520	B2	R2533	C1	R2545	A2	RB201	D1	TA2506	A1	ZD251	B1
C2501	D3	C2513	D2	C2525	A2	C2538	B3	D2504	A2	LD2501	A4	R2508	D1	R2521	B2	R2534	C1	R2546	C4	RB3	D4	TA2507	A1	ZD252	B1
C2502	C4	C2514	B1	C2526	C1	C2539	B3	D2506	A2	LD2502	C4	R2509	D2	R2522	B2	R2535	C1	R2548	D1	RB5001	B4	TA2508	A1	ZD253	B2
C2503	B1	C2515	B1	C2527	C1	C2540	B3	D2507	A2	Q2501	D2	R2510	C2	R2523	B2	R2536	D1	R2549	D1	RB5501	A4	TA2509	A1	ZD254	C2
C2504	B1	C2516	C2	C2528	C1	C2541	B1	D2508	A2	Q2502	C1	R2511	C2	R2524	D2	R2537	D1	R2550	C4	RB701	C4	TA2510	A1	ZD255	D1
C2505	C2	C2517	C2	C2529	D1	C5501	B4	D2509	A2	Q2503	C4	R2512	C2	R2525	D2	R2538	D1	R2551	C4	SN251	C1	TA2511	A1		
C2506	C2	C2518	B4	C2530	D1	C5502	B4	D2510	C3	R2501	D1	R2514	B2	R2526	D2	R2539	D1	R2552	D4	SW701	C4	TA2512	A1		
C2507	C2	C2519	B4	C2531	D1	C5503	B4	DP251	D3	R2502	D2	R2515	B2	R2528	D1	R2540	D1	R2553	D4	TA2501	A1	TA2513	A1		
C2508	C2	C2520	B4	C2532	D1	C5504	B4	FB5501	B4	R2503	C4	R2516	A2	R2529	A1	R2541	B2	R2554	D4	TA2502	A1	TA2514	A1		
C2509	D2	C2521	B2	C2533	B3	C5505	B4	FB5502	B4	R2504	C1	R2517	A2	R2530	A2	R2542	B1	R2555	D4	TA2503	A1	TA2515	A1		
C2510	C3	C2522	A2	C2534	B3	C5506	B4	FB5503	B4	R2505	C1	R2518	A2	R2531	A2	R2543	A2	RB1	D4	TA2504	A1	TA2516	A1		

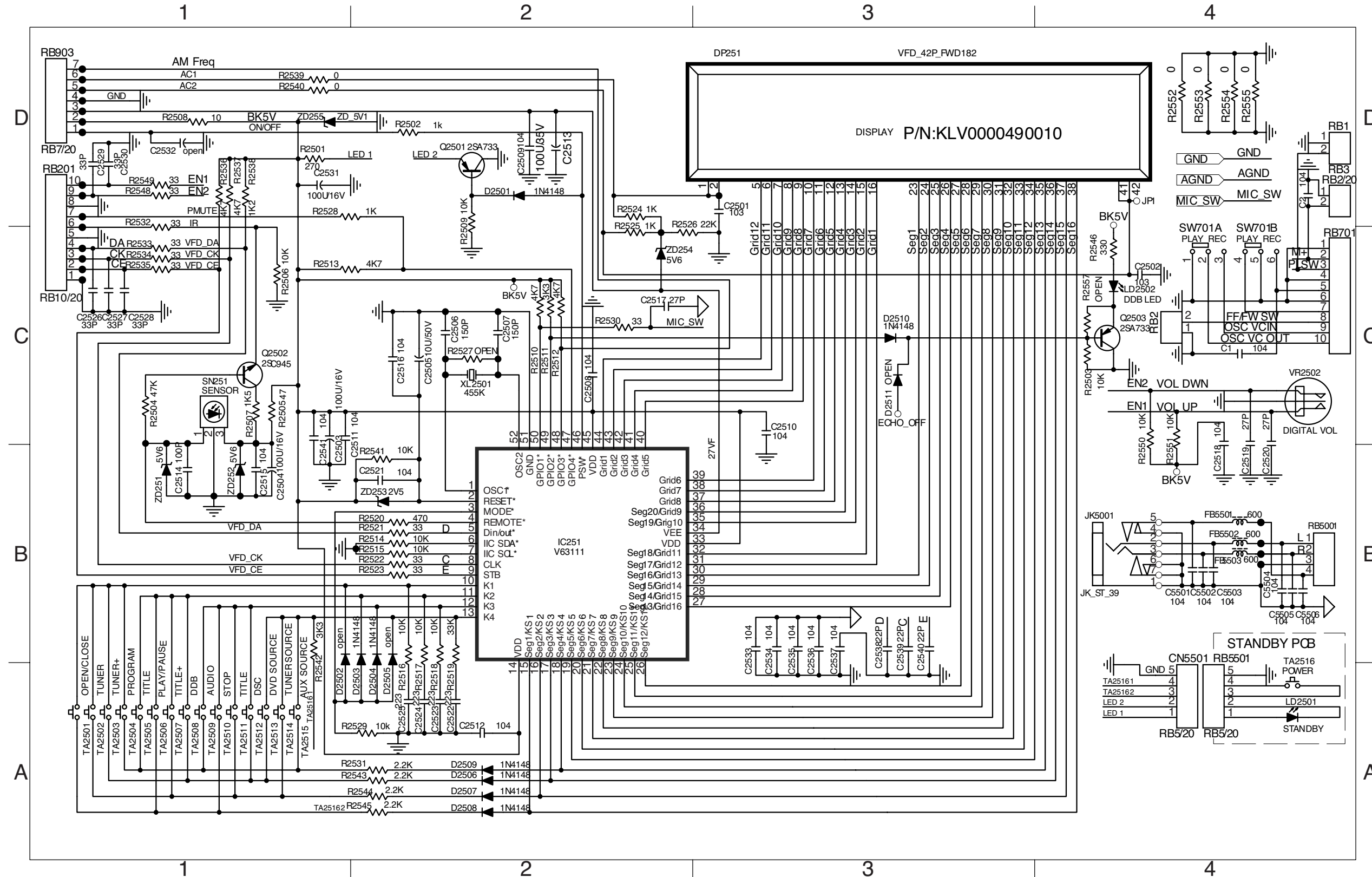

CIRCUIT DIAGRAM : KARAOKE PCB

C2	C3036	B3	C3046	D4	IC3002	D2	Q3007	C2	R3015	C2	R3032	C3	R3043	A3	R3055	C4	R3071	D1	
C2	C3037	B3	C3047	C4	IC3003	B3	R2556	D2	R3016	C2	R3033	C3	R3045	D4	R3056	C4	R3072	B4	
D3	C3038	B3	C3049	C4	JK3001	D1	R3001	D1	R3023	A2	R3034	C3	R3046	D4	R3059	B4			
D3	C3040	B3	C3051	B4	L3001	D1	R3009	D2	R3025	D3	R3035	C3	R3047	D4	R3064	C4			
D3	C3042	A3	C3056	A3	PT2396	A1	R3010	D2	R3026	D3	R3037	B3	R3048	D4	R3065	A4			
C3	C3043	A3	D3001	C2	Q3001	C2	R3011	C2	R3027	C3	R3038	B3	R3050	D4	R3066	A4			
C3	C3044	D4	D3002	C2	Q3003	C3	R3012	C2	R3028	C3	R3039	B3	R3053	C4	R3067	A4			
B3	C3045	D4	D3003	D4	Q3004	D4	R3013	C2	R3030	C3	R3040	B3	R3054	C4	R3070	C2			

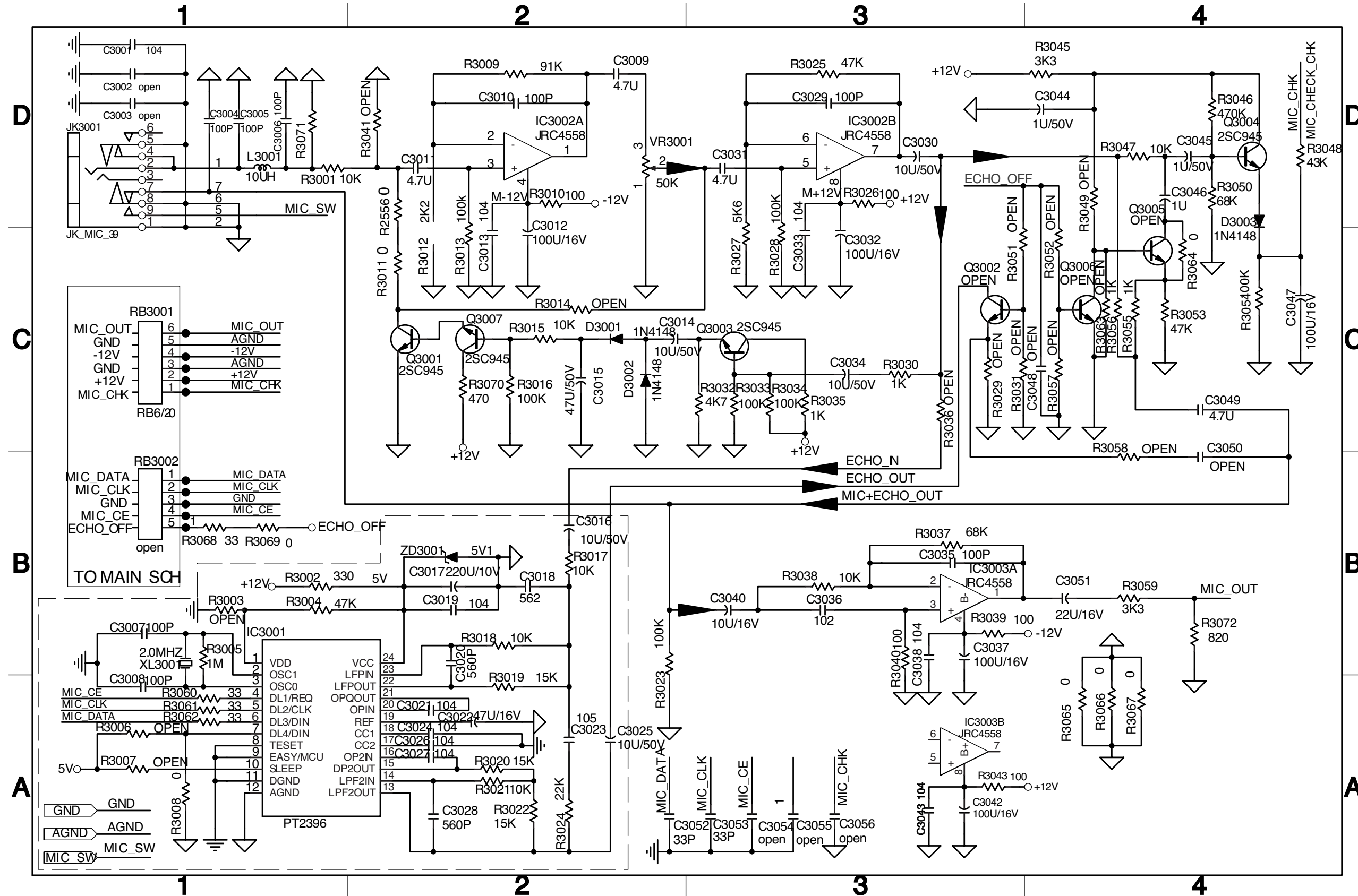

PCB LAYOUT - KEY & KARAOKE (TOP VIEW)

C2503	A2	C3044	B1	J11	A2	J22	B5	J34	C2	J45	A4	J8	C2	R2514	A4	R2546	A5	TA2505	B4	TP1	C5
C2504	A5	C3045	B1	J12	A2	J23	B4	J35	C2	J46	A4	J9	C2	R2515	A3	R2550	A5	TA2506	C3	TP2	C1
C2505	A3	C3046	B1	J13	A2	J24	B4	J36	C3	J47	A3	JK3001	C1	R2516	A3	R2551	A5	TA2507	C4	VR2502	A5
C2513	B2	C3047	B1	J14	B2	J25	C4	J37	C3	J48	A3	JK5001	C5	R2517	A3	R3011	B1	TA2508	B5	VR3001	B1
C2531	C1	C3051	A1	J15	B2	J26	C4	J38	C3	J49	A2	LD2501	A1	R2518	A3	R3048	B1	TA2509	C4	VR3001	B1
C3014	B1	D2501	A2	J16	A2	J27	C3	J39	C3	J5	B1	LD2502	B5	R2519	A3	RB3	A5	TA2510	C3	XL2501	A3
C3015	B1	D2503	A3	J17	A2	J28	C3	J4	C1	J50	A2	R2501	A2	R2520	A5	RB5001	C5	TA2511	C2	XL2501	A3
C3030	B1	D2504	A3	J18	A3	J29	B1	J40	B3	J51	C3	R2508	C1	R2521	A3	RB5501	A1	TA2512	A1	XL3001	B1
C3034	B1	D2510	A2	J19	A4	J3	C1	J41	B4	J52	A4	R2510	A3	R2522	A4	RB701	A5	TA2513	B2	ZD255	C1
C3037	A1	DP251	A2	J2	B1	J30	C2	J42	B4	J53	C4	R2511	A2	R2523	A4	TA2502	C2	TA2514	B3	ZD255	C1
C3040	A1	J1	A1	J20	A4	J32	A5	J43	B5	J6	C1	R2512	A2	R2530	C2	TA2503	C4	TA2515	B4	ZD3001	B1
C3042	A1	J10	C2	J21	A4	J33	C2	J44	B5	J7	C2	R2513	A2	R2542	A4	TA2504	C2	TA2516	A1		

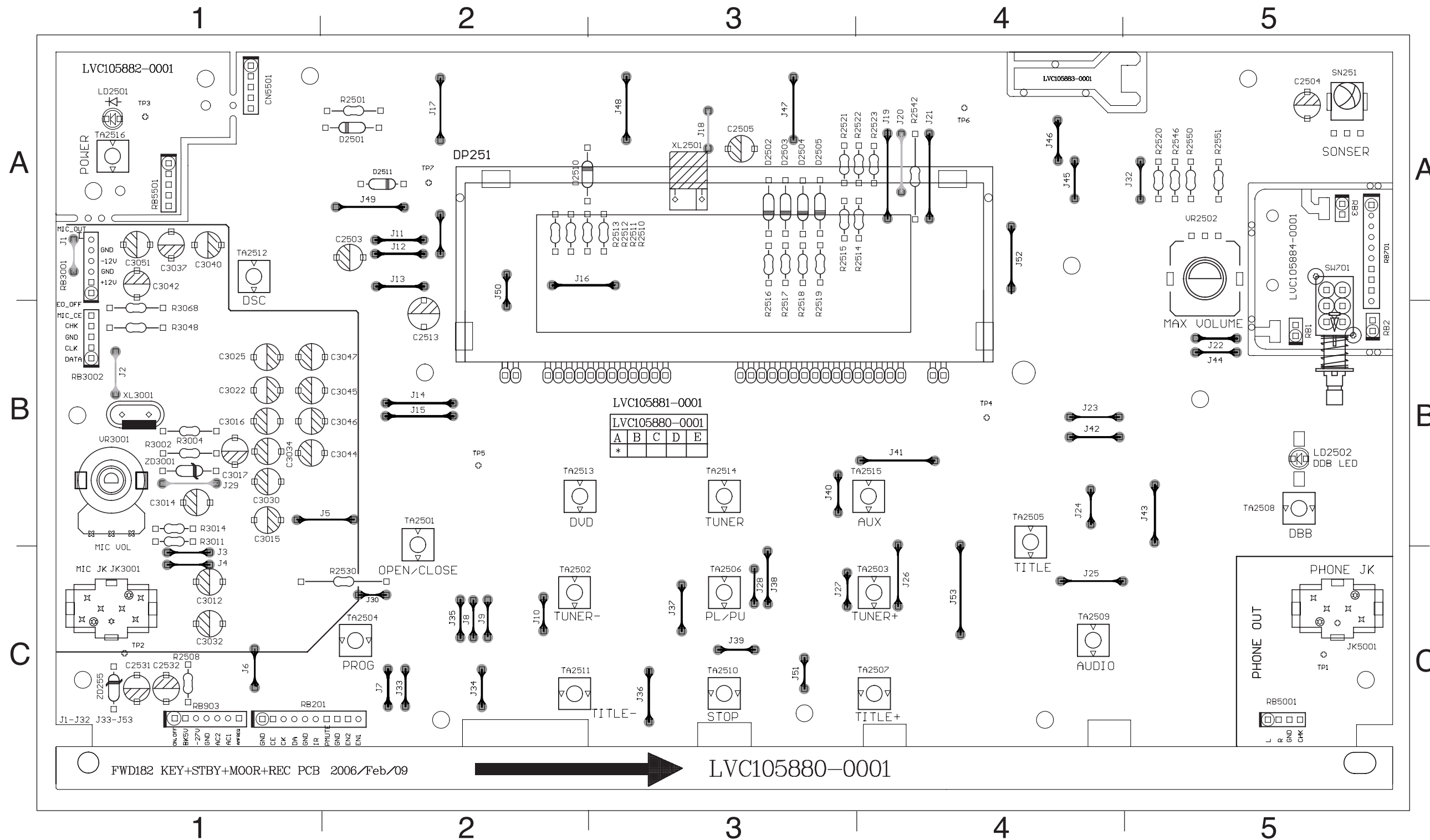

PCB LAYOUT - KEY & KARAOKE (BOTTOM VIEW)

C1	A5	C2518	A5	C2535	A1	C3035	A1	C5504	C5	IC3003	A1	R2509	A1	R2540	C1	R3013	C1	R3038	A1	R3065	C1
C2	A5	C2519	A5	C2536	C5	C3036	A1	C5505	C5	L3001	B1	R2524	C1	R2541	A3	R3015	B1	R3039	A1	R3066	C1
C2501	B2	C2520	A5	C2538	A3	C3038	A1	C5506	C5	Q2501	A1	R2525	C1	R2543	B4	R3016	B1	R3040	A1	R3067	C1
C2502	B4	C2521	A3	C2539	A4	C3043	A1	D2506	B3	Q2502	A5	R2526	C1	R2544	B4	R3023	B1	R3043	A1	R3070	B1
C2506	A3	C2522	A3	C2540	A4	C3048	B2	D2507	B3	Q2503	B5	R2528	C2	R2545	B4	R3025	C1	R3045	B2	R3071	C1
C2507	A3	C2523	A3	C2541	A3	C3049	B2	D2508	B3	Q3001	B1	R2529	A3	R2548	C2	R3026	C1	R3046	B1	R3072	A1
C2508	A5	C2524	A3	C3001	B1	C3050	B2	D2509	B3	Q3003	B1	R2531	B4	R2549	C2	R3027	C1	R3047	B2	ZD251	A5
C2509	C1	C2525	A3	C3004	C1	C3052	B1	D3001	B1	Q3004	B2	R2532	C1	R2552	C2	R3028	C1	R3049	B2	ZD252	A5
C2510	A2	C2526	C1	C3005	C1	C3053	B1	D3002	B1	Q3007	B1	R2533	C1	R2553	C2	R3029	B2	R3050	B1	ZD253	A3
C2511	C1	C2527	C1	C3006	B1	C3054	B1	D3003	B2	R2502	C1	R2534	C1	R2554	B2	R3030	B2	R3053	B2	ZD254	C1
C2512	A3	C2528	C1	C3009	C1	C3055	B1	FB5501	C5	R2503	B5	R2535	C1	R2555	B3	R3032	B1	R3054	B2		
C2514	A5	C2529	C2	C3013	C1	C3056	A1	FB5502	C5	R2504	A5	R2536	C1	R3001	B1	R3033	B1	R3055	B2		
C2515	A5	C2530	C2	C3029	C1	C5501	C5	FB5503	C5	R2505	A5	R2537	C1	R3009	C1	R3034	B1	R3056	B1		
C2516	A3	C2533	C5	C3031	C1	C5502	C5	IC251	A3	R2506	C1	R2538	C1	R3010	C1	R3035	B1	R3059	A1		
C2517	C1	C2534	C5	C3033	C1	C5503	C5	IC3002	C1	R2507	A5	R2539	C1	R3012	C1	R3037	A1	R3064	B2		

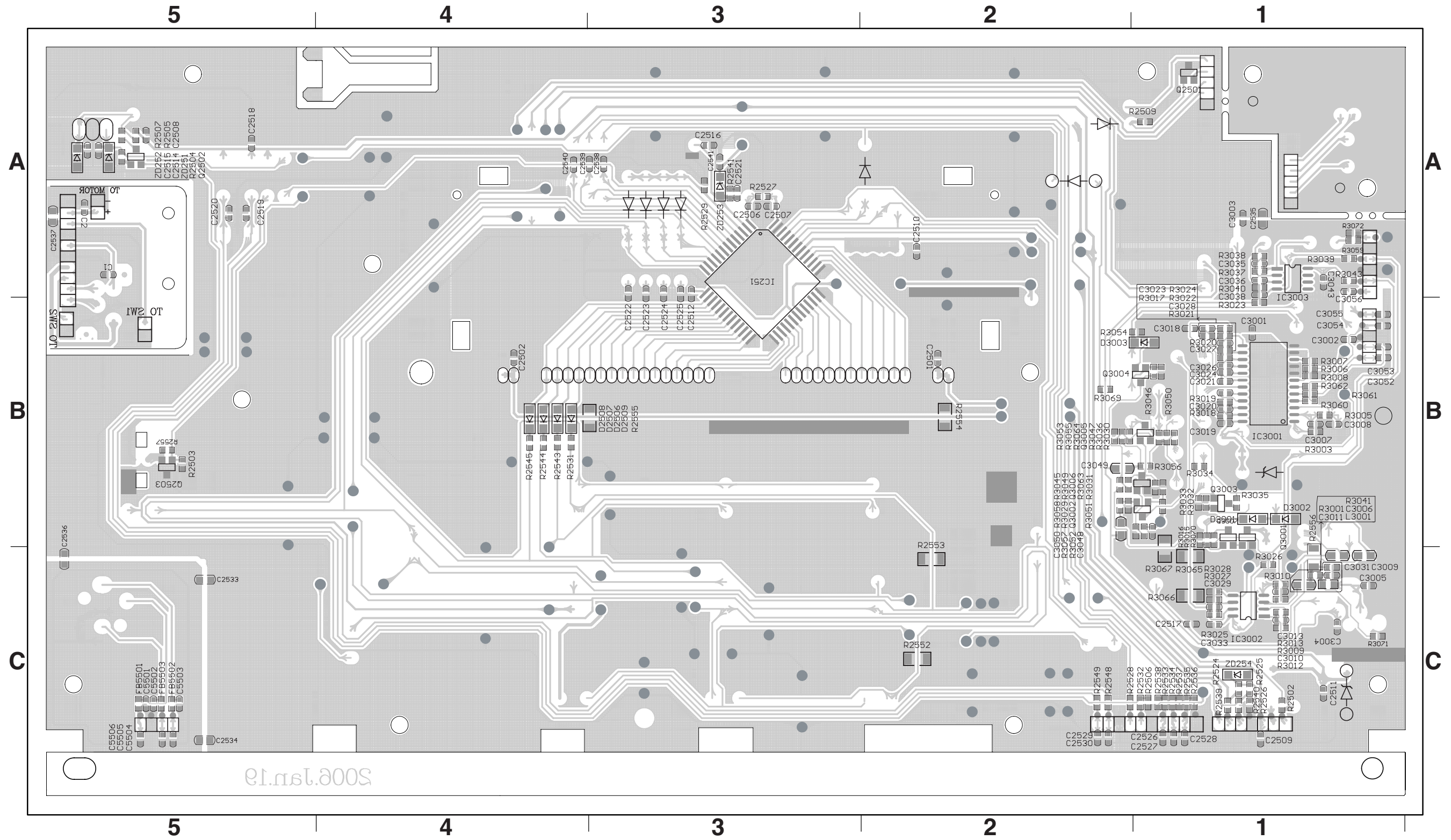

ELECTRICAL PARTS LIST - KEY & KARAOKE BOARD

D2506	4822 130 83338	LL4148
D2507	4822 130 83338	LL4148
D2508	4822 130 83338	LL4148
D2509	4822 130 83338	LL4148
D3001	4822 130 83338	LL4148
D3002	4822 130 83338	LL4148
D3003	4822 130 83338	LL4148
DP251	9940 000 05263	VFD 42P 70X22MM
IC251	9940 000 05266	IC 52P V63111 QFP
IC3002	9965 000 29611	IC 8P CO4558A SO8 CERAMATE
IC3003	9965 000 29611	IC 8P CO4558A SO8 CERAMATE
JK3001	9940 000 05256	KARAOKE JACK D3.5MM 9P
JK5001	9940 000 05257	PHONE JACK D3.5
LD2501	9940 000 05258	LED D3 RED ROUND
LD2502	9940 000 01561	LED 3DIA SUPER RED LENS
Q2501	9940 000 00915	XISTR NPN 2SC1623
Q2501	9940 000 00921	XISTR PNP 2SA812 HFE:200-400
SN251	9940 000 05259	IRT RECEIV. IRM-2638F4
SW701	9940 000 05261	SW PUSH PS-22F03-BNL-80
TA2501	9940 000 00872	TACT SW 50MA 12V
TA2502	9940 000 00872	TACT SW 50MA 12V
TA2503	9940 000 00872	TACT SW 50MA 12V
TA2504	9940 000 00872	TACT SW 50MA 12V
TA2505	9940 000 00872	TACT SW 50MA 12V
TA2506	9940 000 00872	TACT SW 50MA 12V
TA2507	9940 000 00872	TACT SW 50MA 12V
TA2508	9940 000 00872	TACT SW 50MA 12V
TA2509	9940 000 00872	TACT SW 50MA 12V
TA2510	9940 000 00872	TACT SW 50MA 12V
TA2511	9940 000 00872	TACT SW 50MA 12V
TA2512	9940 000 00872	TACT SW 50MA 12V
TA2513	9940 000 00872	TACT SW 50MA 12V
TA2514	9940 000 00872	TACT SW 50MA 12V
TA2515	9940 000 00872	TACT SW 50MA 12V
TA2516	9940 000 00872	TACT SW 50MA 12V
VR2502	9965 000 23589	ENCODER L20 A=12
VR3001	9940 000 01563	CNTL ROTARY 50KΩ
XL2501	9940 000 05262	RESONATOR CSB 455EB
ZD251	9965 000 26930	CHIP ZENER 5.6V 0.05 0.5W (E2)
ZD252	9965 000 26930	CHIP ZENER 5.6V 0.05 0.5W (E2)
ZD253	9940 000 05264	CHIP ZENER 3.0V 5% 0.5W
ZD254	9940 000 05265	CHIP ZENER 3.9V 5% 0.5W
ZD255	9965 000 26942	DIODE ZENR 5.0-5.2V 0.5W

Note: Only these parts mentioned in the list are normal service parts.

MAIN BOARD

TABLE OF CONTENTS

INTERNAL IC DIAGRAM	6-1
Circuit Diagram Servo (Top Left)	6-2
Circuit Diagram Servo (Top Right)	6-3
Circuit Diagram Servo (Bottom Left)	6-4
Circuit Diagram Servo (Bottom Right)	6-5
Circuit Diagram Amplifier Top	6-6
Circuit Diagram Amplifier Bottom	6-7
PCB Layout Top View	6-8
PCB Layout Bottom View	6-9
Voltage List	6-10
Electrical Parts List	6-11

ES8380 PHOENIX INTERNAL IC DIAGRAM

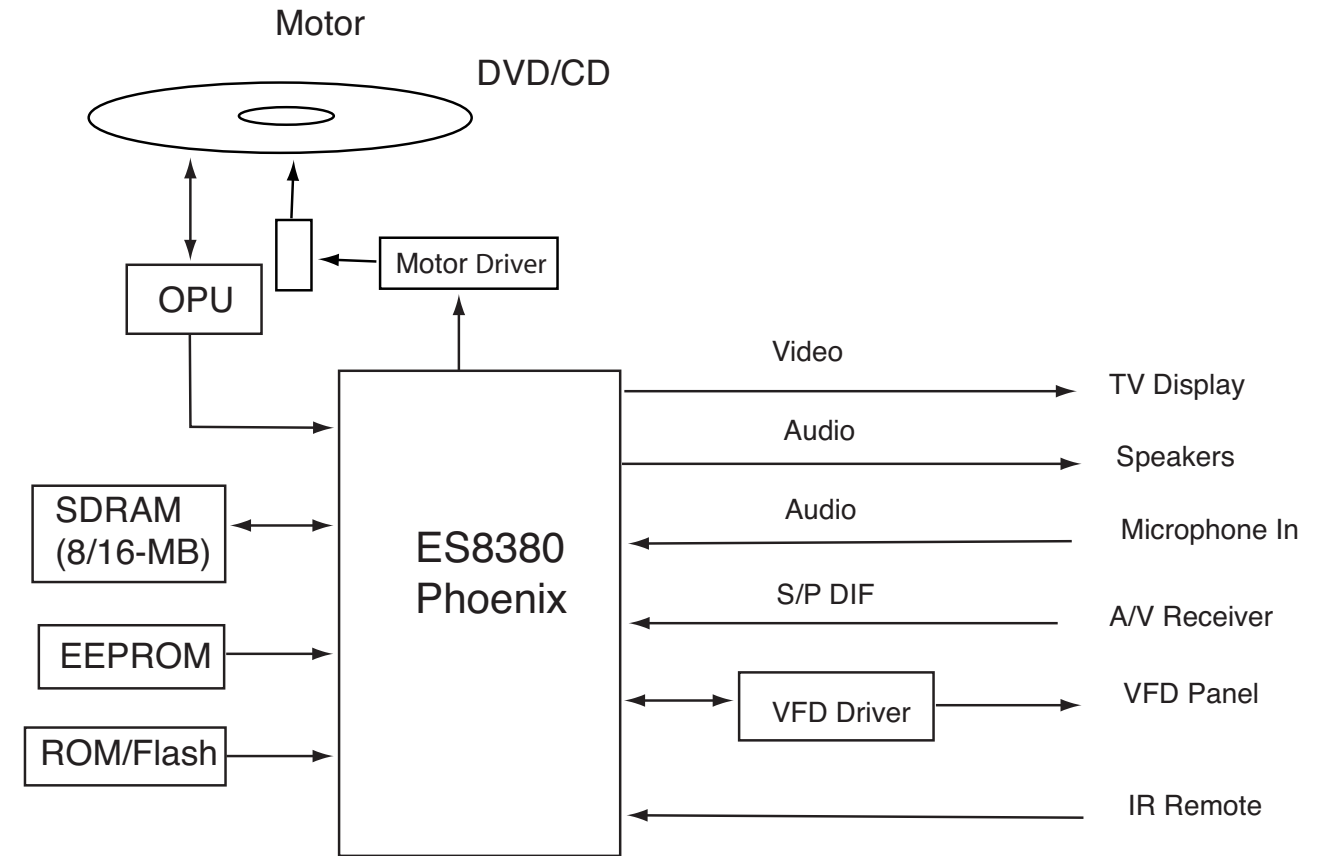

AN7312 INTERNAL IC DIAGRAM

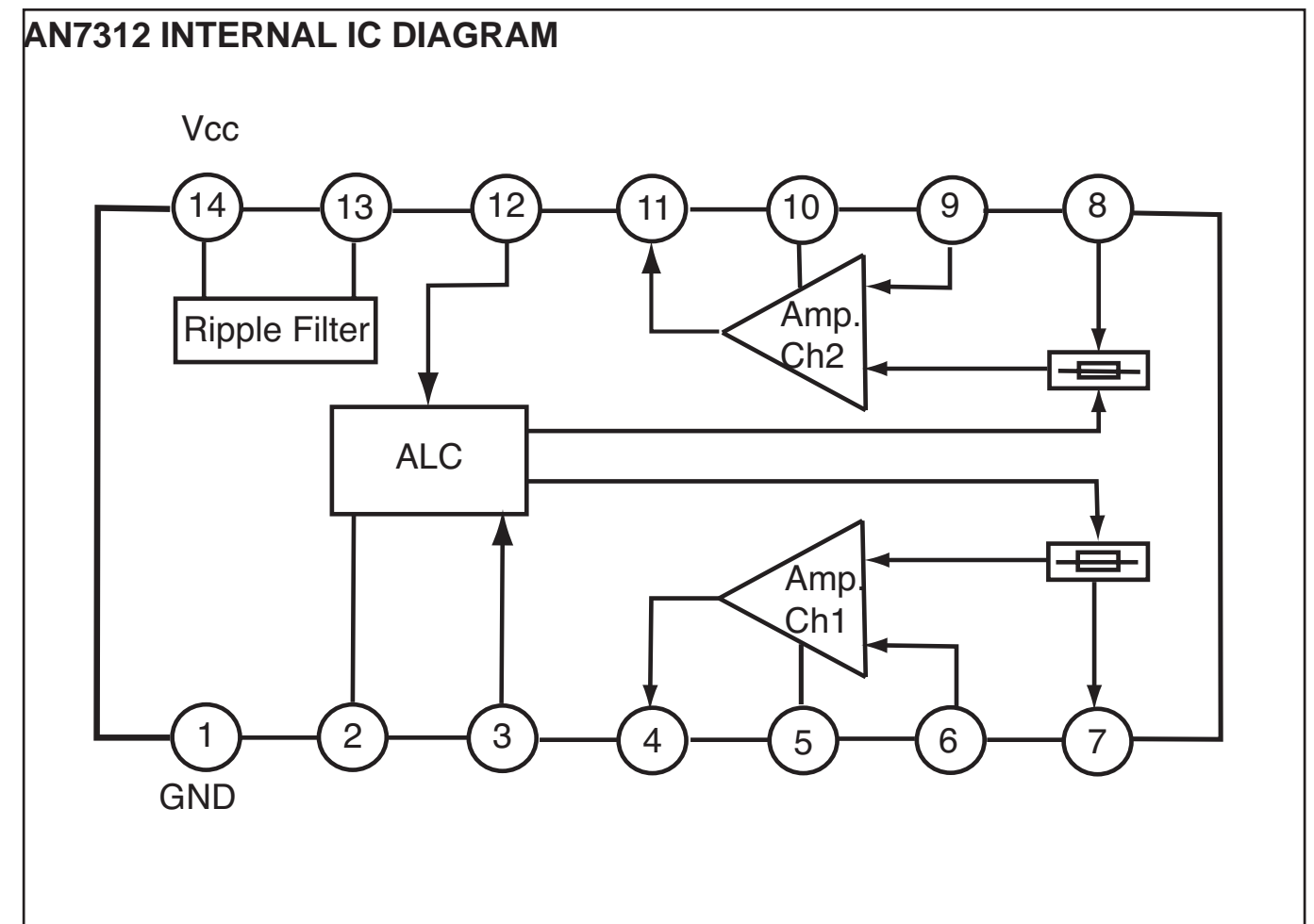

CIRCUIT DIAGRAM MAIN SERVO (TOP LEFT)

C0201	A1	C0216	D4	C0232	A7	C2003	C8	C206	B1	C223	B2	C238	B3	C253	B4	C269	C4	C285	D6	C322	D7	C803	D2	CE4	A1	D802	D2	FB214	B3
C0202	A1	C0217	D4	C0233	A3	C2004	C8	C207	B1	C224	D5	C239	B3	C254	B4	C270	D6	C286	D6	C324	D7	C804	D2	CE5	A1	D803	D3	FB215	D6
C0203	A1	C0218	C7	C0234	A4	C2006	C8	C208	A2	C225	C7	C240	B3	C255	A4	C271	D6	C287	D6	C326	C7	C805	C2	CE6	A1	D804	D3	FB216	D5
C0204	A1	C0219	C7	C0235	B4	C2007	C8	C209	A2	C226	A2	C241	B3	C256	A4	C272	D6	C288	D6	C327	D7	C806	C2	CE7	A2	FB201	B1	FB217	D6
C0205	A1	C0220	C7	C0236	B4	C2008	C7	C210	A3	C227	C3	C242	B2	C258	D5	C273	D5	C289	D6	C328	D7	C807	D3	CE8	A2	FB202	B1	FB218	A5
C0206	A1	C0222	B4	C0237	C4	C2009	C7	C211	A3	C228	C3	C243	C4	C259	D4	C274	D5	C290	D6	C329	D7	C808	D3	CE9	A2	FB203	B1	FB219	D6
C0207	A2	C0223	C8	C0238	B1	C201	B1	C212	B1	C229	C3	C244	C4	C260	D5	C275	D6	C291	C7	C330	D7	C809	D3	CN201	B1	FB204	B1	FB220	D6
C0208	A2	C0224	B8	C0239	B2	C2010	C8	C213	B1	C230	B3	C245	C4	C261	D4	C276	D6	C292	C7	C331	D7	C810	D3	CN801	D1	FB205	B1	FB221	D6
C0209	A2	C0225	A8	C0240	B2	C2011	A8	C214	B1	C231	B3	C246	C4	C262	C5	C277	D6	C293	C6	C332	D7	C811	D3	CN802	C1	FB206	B1	FB222	C7
C0210	A2	C0226	A8	C0241	D5	C2012	B8	C215	B1	C232	B3	C247	C4	C263	C5	C279	D6	C294	C6	C333	D8	C812	C3	CN803	C1	FB207	B1	FB223	D5
C0211	A2	C0227	A8	C0243	A2	C2013	C7	C216	B1	C233	B3	C248	B4	C264	C5	C280	D6	C295	C7	C334	D8	C813	C3	D201	D4	FB208	B1	FB224	D4
C0212	A2	C0228	A8	C0244	C6	C202	B1	C217	B2	C234	B3	C249	B4	C265	C5	C281	D6	C296	C7	C335	D8	C815	C3	D202	D5	FB209	B1	FB225	A8
C0213	D3	C0229	A8	C0245	A3	C203	B1	C218	B1	C235	B3	C250	B4	C266	C5	C282	D6	C297	B7	C336	D8	CE1	A1	D203	D5	FB210	A2	FB226	A8
C0214	D4	C0230	A8	C0246	A3	C204	B1	C219	C7	C236	B3	C251	B4	C267	C5	C283	D6	C298	A6	C801	D1	CE2	A1	D204	D5	FB211	C4	FB227	C7
C0215	D4	C0231	A8	C2002	C8	C205	B1	C222	B2	C237	B3	C252	B4	C268	C5	C284	D6	C321	C7	C802	D2	CE3	A1	D801	D2	FB213	B4	FB228	C8

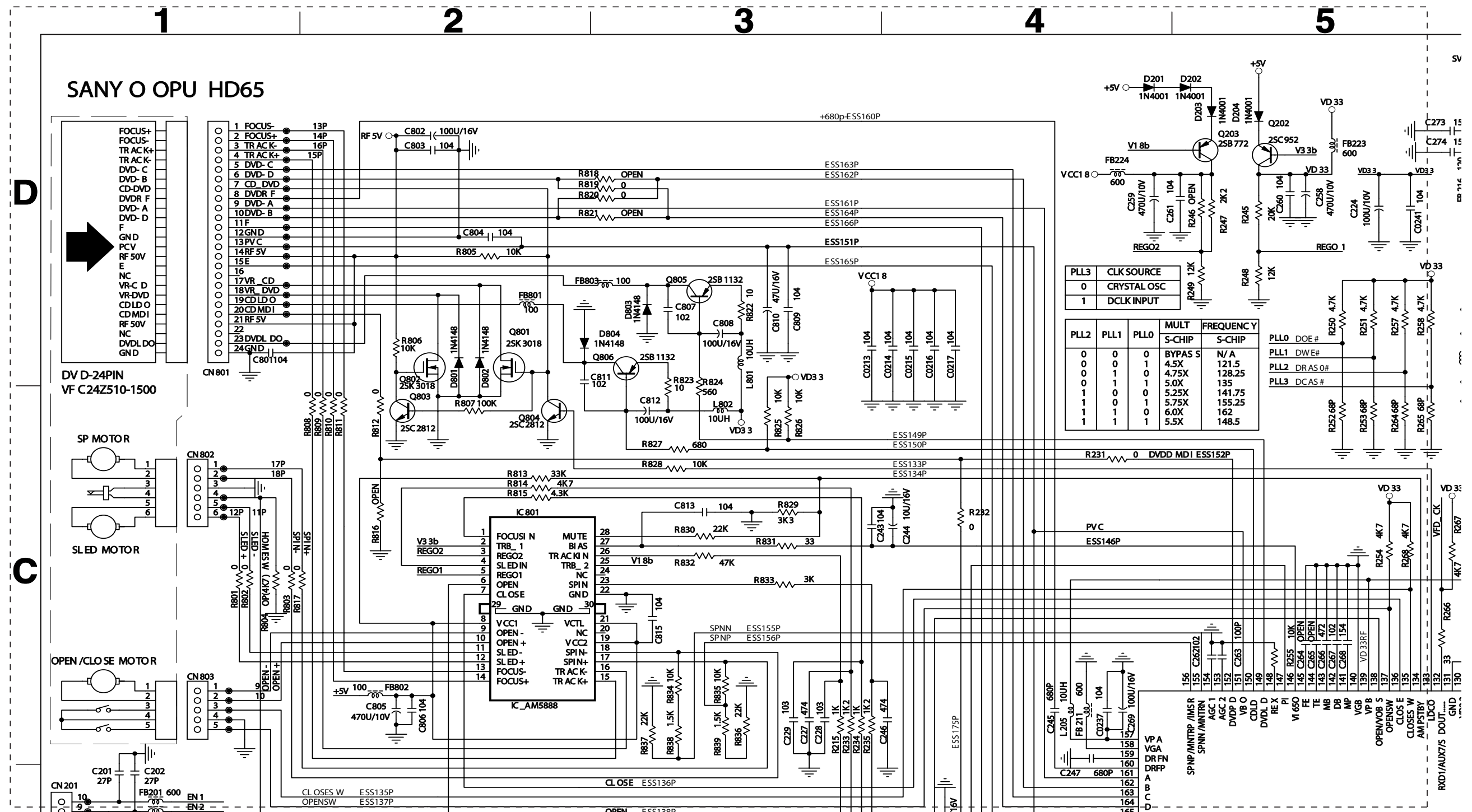

CIRCUIT DIAGRAM MAIN SERVO (TOP RIGHT)

FB229	C7	IC209	A3	L210	D6	Q805	D3	R208	A4	R226	A3	R243	A4	R260	C6	R278	C6	R329	D7	R809	C2	R827	C3	RA204	A4	ZD211	D6
FB301	D7	IC210	A3	L211	D6	Q806	D3	R209	A3	R227	A3	R244	A4	R261	C6	R279	B7	R330	D7	R810	C2	R828	C3	RA205	A5	ZD212	D6
FB302	D8	IC303	D8	L212	C7	R201	B4	R210	A2	R228	A3	R245	D5	R262	C6	R281	B7	R331	D7	R811	C2	R829	C3	RA206	A5		
FB303	D8	IC801	C2	L213	C7	R2015	A2	R212	A2	R230	A2	R247	D5	R263	C6	R282	B7	R332	D7	R812	C2	R830	C3	RA207	A8		
FB304	D8	JK201	B1	L214	C7	R2016	A2	R214	B2	R231	C4	R248	D5	R264	C5	R283	A7	R334	C8	R813	C2	R831	C3	XL201	B3		
FB801	D2	JK202	D6	L215	A8	R2017	A2	R215	C3	R232	C4	R249	D5	R265	C5	R284	C8	R335	D8	R814	C2	R832	C3	ZD201	D6		
FB802	C2	JK203	D6	L801	C3	R2018	A2	R216	B3	R233	C3	R250	D5	R266	C5	R285	C8	R336	D8	R815	C2	R833	C3	ZD202	D6		
FB803	D3	L202	B2	L802	C3	R2019	A2	R217	B3	R234	C3	R251	D5	R267	C5	R287	C8	R339	D8	R817	C1	R834	C3	ZD203	D6		
IC201	B6	L203	B2	Q201	A3	R202	B4	R218	B3	R235	C3	R252	C5	R268	C5	R288	C8	R801	C1	R819	D3	R835	C3	ZD204	D6		
IC202	A7	L204	A3	Q202	D5	R2022	A4	R219	B3	R236	B4	R253	C5	R269	C6	R289	A8	R802	C1	R820	D3	R836	C3	ZD205	D6		
IC203	B8	L205	C4	Q203	D5	R203	B4	R220	A8	R237	B4	R254	C5	R270	C7	R290	A8	R803	C1	R822	D3	R837	C3	ZD206	D6		
IC204	A4	L206	D6	Q801	D2	R204	B1	R221	A3	R239	B4	R255	C5	R271	C7	R291	A8	R805	D2	R823	D3	R838	C3	ZD207	D6		
IC205	A7	L207	D6	Q802	D2	R205	B1	R222	A3	R240	B3	R257	C5	R273	C7	R292	A8	R806	D2	R824	D3	R839	C3	ZD208	D6		
IC206	A3	L208	D6	Q803	C2	R206	B1	R223	A3	R241	B4	R258	C5	R274	C7	R327	D7	R807	C2	R825	C3	RA202	B4	ZD209	D6		
IC207	B2	L209	D6	Q804	C2	R207	B4	R225	A3	R242	A4	R259	C6	R275	C7	R328	D7	R808	C2	R826	C3	RA203	A4	ZD210	D6		

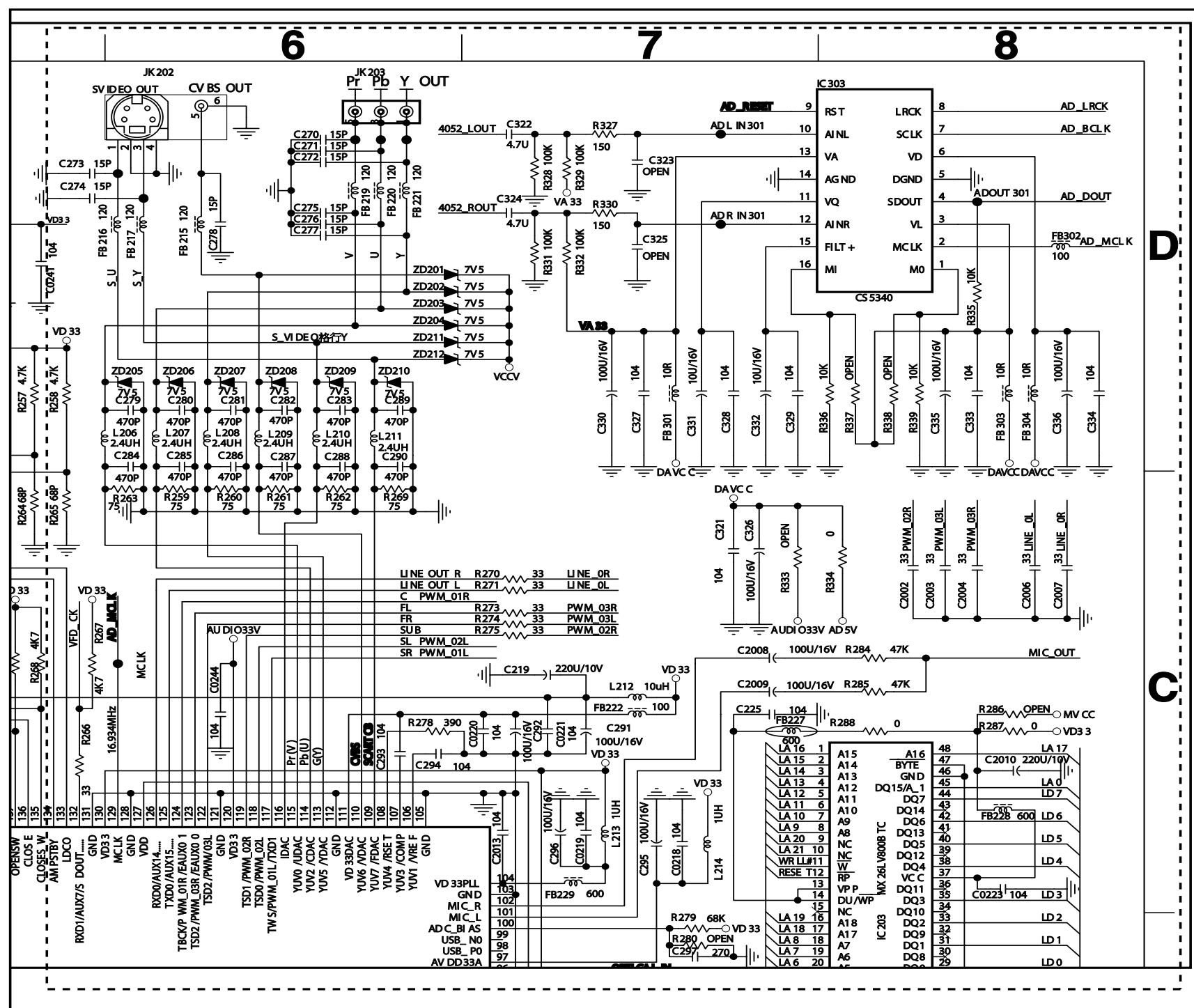

CIRCUIT DIAGRAM MAIN SERVO (BOTTOM LEFT)

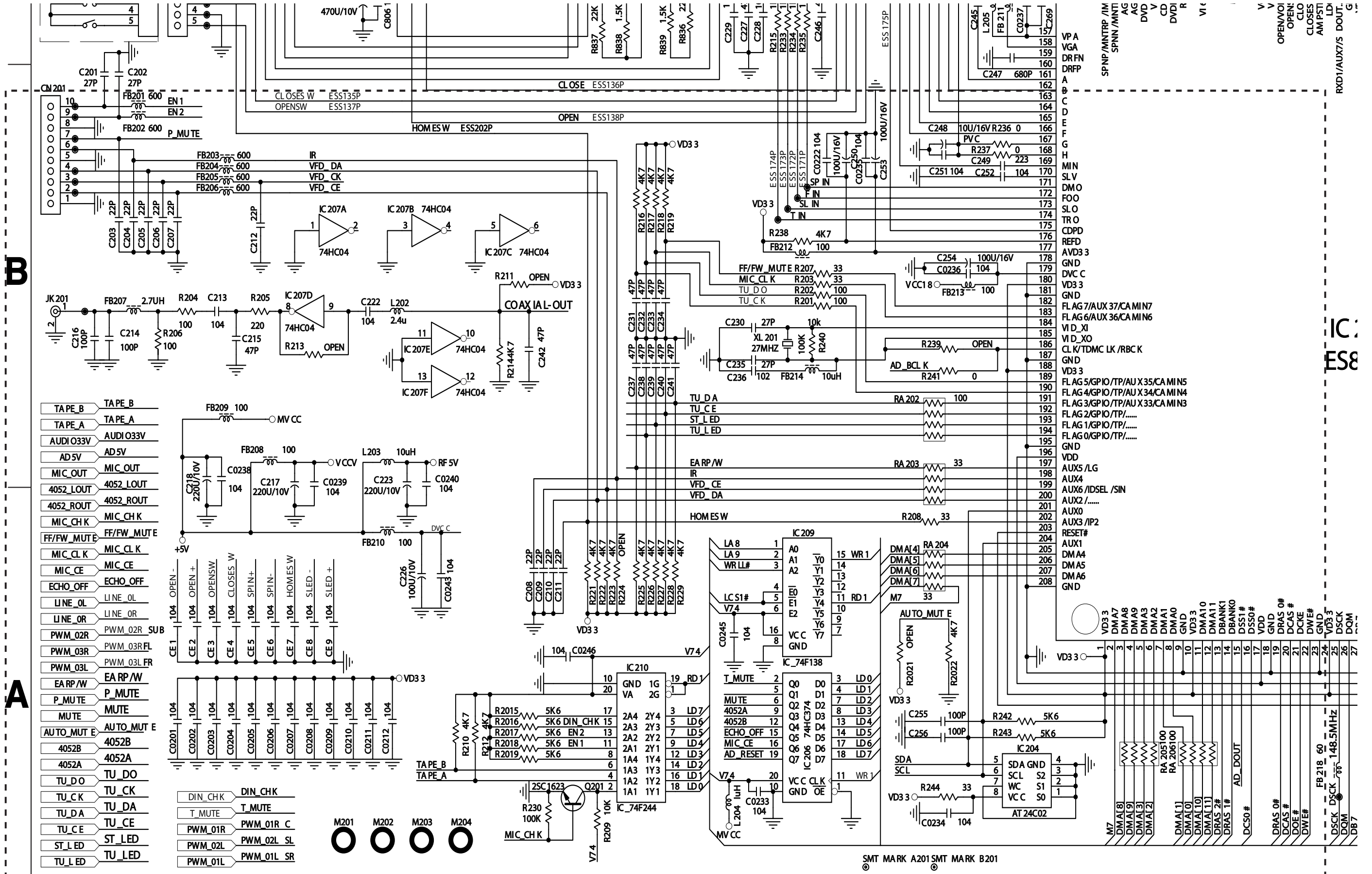

B

A

1

2

3

4

5

IC:
ES8

SMT MARK A201 SMT MARK B201

CIRCUIT DIAGRAM MAIN SERVO (BOTTOM RIGHT)

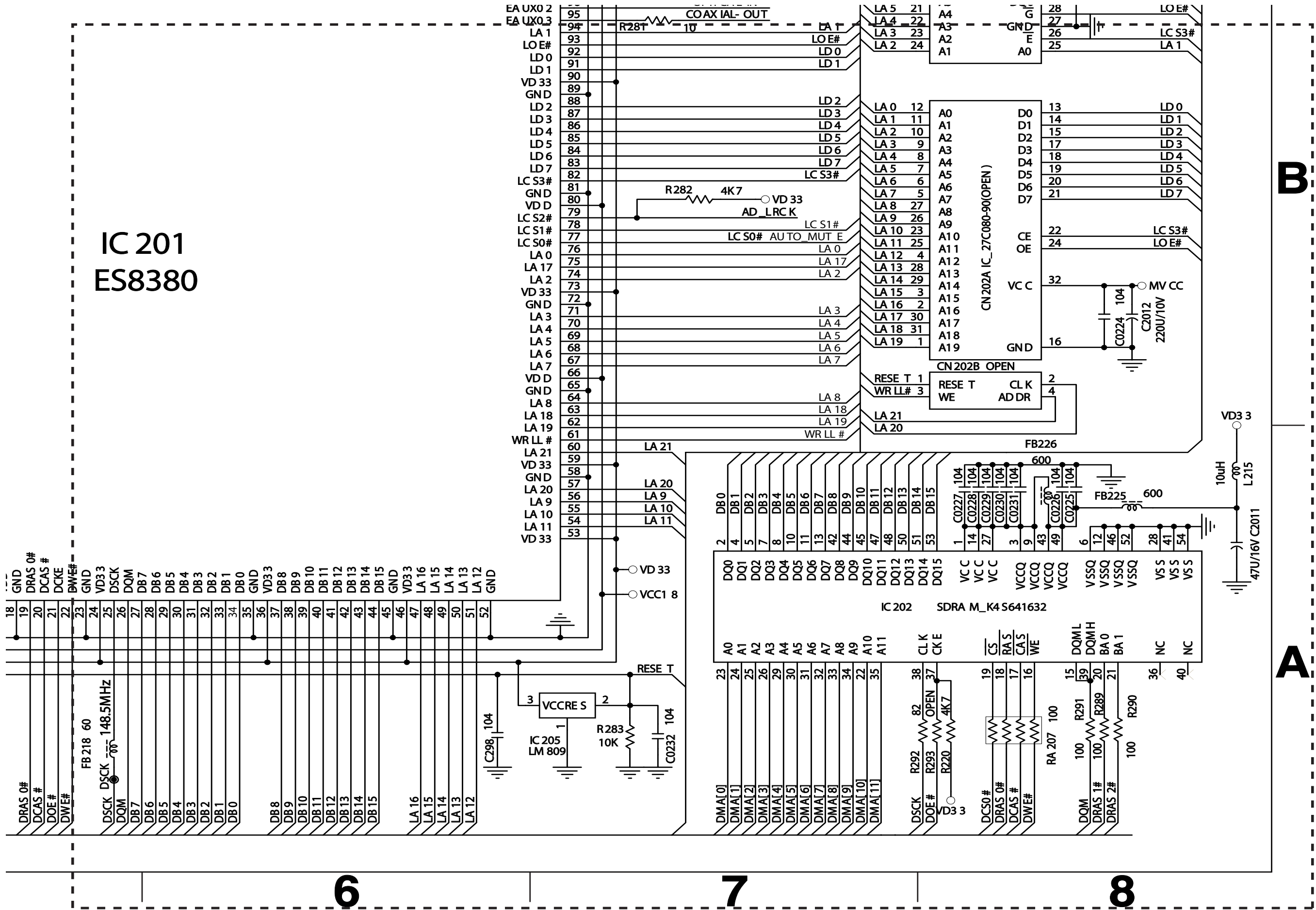

6

7

8

B

A

CIRCUIT DIAGRAM MAIN AMPLIFIER (TOP)

C301	D1	C316	D3	C409	C6	C427	A5	C442	A6	C5003	B7	C505	A6	C520	A6	C707	C2	C723	B3	C901	B2	C916	A3	D501	A7	D521	C8	IC302	D3	L501	A6
C302	D1	C317	D4	C410	C6	C428	A5	C443	A6	C5004	B7	C506	A6	C521	D5	C708	C2	C724	B3	C902	B2	C917	A3	D502	D5	D701	B3	IC401	C6	L502	A6
C303	C1	C318	D4	C411	C6	C429	A5	C444	A6	C5005	B7	C507	A6	C522	D6	C709	C2	C725	B2	C903	B2	C918	A3	D503	D5	FB305	D1	IC402	C6	Q401	C7
C304	C1	C319	D4	C412	C6	C430	A5	C445	A6	C5006	B7	C508	A6	C523	D5	C710	B2	C726	B2	C904	A2	C919	A4	D504	D5	FB306	D1	IC5001	B7	Q402	C7
C305	D2	C320	D3	C413	C6	C431	A5	C446	A6	C5007	B7	C509	A6	C525	D6	C711	B2	C727	B2	C905	A2	C920	A4	D505	D5	FB307	D1	IC5002	B6	Q403	C8
C306	D2	C347	A4	C414	C6	C432	A5	C447	A6	C5008	B8	C510	A6	C526	D6	C712	B2	C729	C4	C906	A2	C921	A4	D506	D5	FB308	D1	IC502	A6	Q404	C8
C307	D2	C348	A5	C416	C7	C433	A5	C448	A6	C5009	B8	C511	A6	C548	B7	C713	B2	C731	C4	C907	A2	C922	A4	D507	D5	FB309	D1	IC503	A7	Q405	B8
C308	D2	C401	C6	C417	C8	C434	A5	C449	A6	C5010	B8	C512	A6	C549	A5	C714	C3	C733	C4	C908	A2	C923	A3	D508	D5	FB401	C8	IC701	C2	Q410	C8
C309	D2	C402	C6	C418	C8	C435	A5	C450	A7	C5010	B8	C513	A6	C550	A5	C715	C3	C734	C4	C909	A2	C924	A4	D509	D5	FB402	C8	IC703	C4	Q5001	B8
C310	D2	C403	C6	C419	B6	C436	A6	C451	A7	C5011	B8	C514	A6	C551	C8	C717	C3	C735	C4	C910	A2	CN3001	A1	D510	D6	FB403	C8	JK401	D1	Q5002	B7
C311	D3	C404	C6	C420	B6	C437	A6	C452	A7	C5012	B6	C515	B7	C702	C2	C718	C3	C736	C4	C911	A3	CN301	D1	D511	D6	FB901	B2	JK402	D8	Q501	D5
C312	D3	C405	C6	C421	B6	C438	A6	C453	A7	C5013	B6	C516	A7	C703	C2	C719	C3	C737	B3	C912	A3	CN5001	B8	D512	D6	FB902	A2	JK501	A6	Q502	D6
C313	D3	C406	C6	C424	A5	C439	A6	C456	D7	C5014	B6	C517	A7	C704	C2	C720	C3	C738	A5	C913	A3	CN701	C1	D513	D6	FB903	A2	L5001	B8	Q503	D5
C314	D3	C407	C6	C425	A5	C440	A6	C5001	B7	C5015	B6	C518	A7	C705	C2	C721	C3	C739	A5	C914	A3	CN702	C1	D519	C7	FB904	A2	L5002	B8	Q504	D6
C315	D2	C408	C6	C426	A5	C441	A6	C5002	B7	C504	A6	C519	A6	C706	C2	C722	C3	C740	A5	C915	A3	D5001	B7	D520	D6	IC301	D2	L5003	B8	Q505	D6

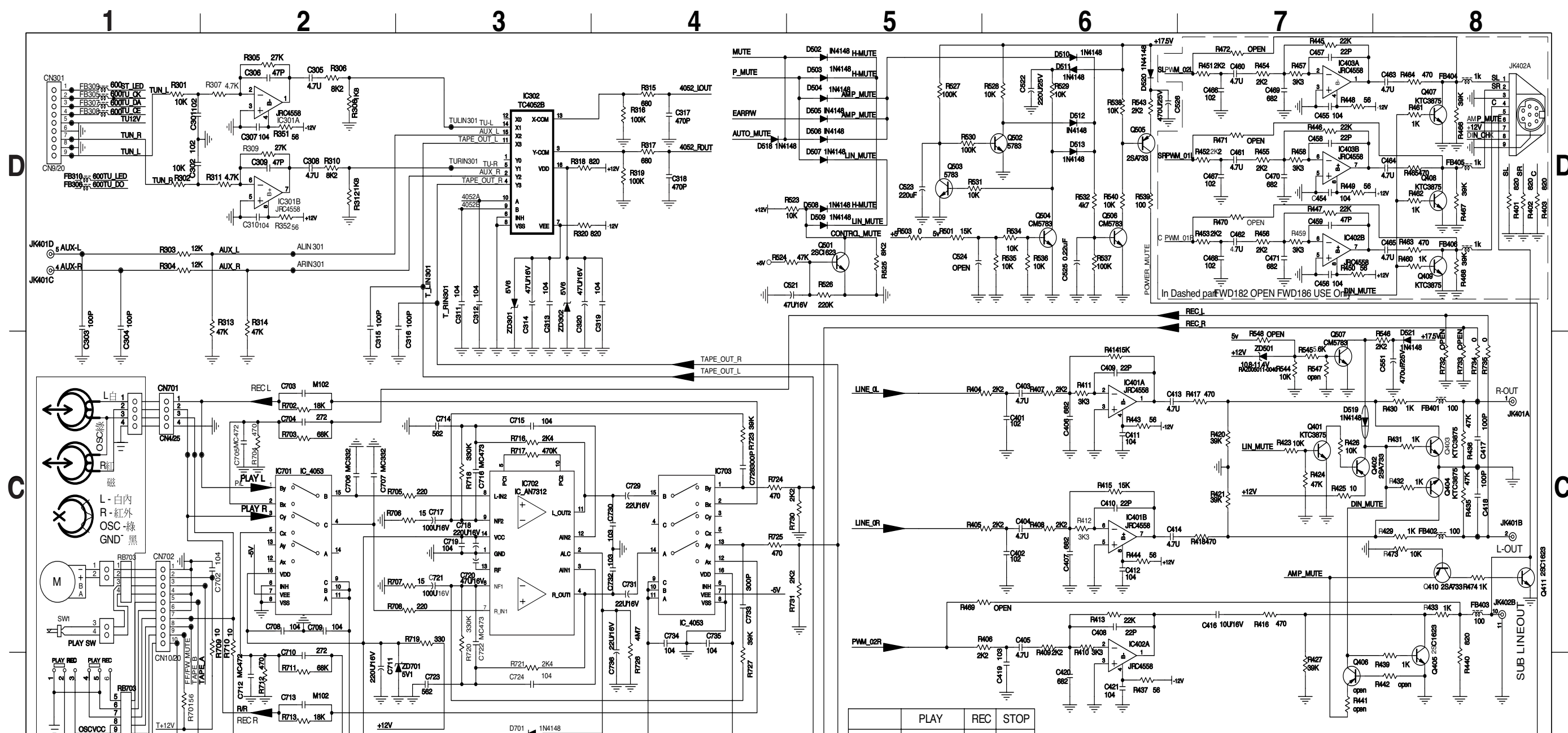

CIRCUIT DIAGRAM MAIN AMPLIFIER (BOTTOM)

Q506	D6	R303	D1	R320	D3	R417	C7	R436	C8	R5006	B7	R509	A6	R524	D5	R540	D6	R709	C2	R727	B4	R744	B3	ZD302	D3
Q507	C7	R304	D1	R351	D2	R418	C7	R437	B6	R5007	B7	R510	A6	R525	D5	R541	A5	R710	C2	R728	B3	R746	B4	ZD501	C7
Q701	B3	R305	D2	R352	D2	R420	C7	R439	B8	R5008	B8	R511	A6	R526	D5	R542	A5	R711	B2	R729	B3	R747	B5	ZD701	B3
Q702	B4	R306	D2	R404	C6	R421	C7	R440	B8	R5009	B8	R512	A7	R527	D5	R543	D6	R712	B2	R730	C5	R748	B5	ZD702	A5
Q703	B4	R309	D2	R405	C6	R423	C7	R442	B8	R501	D5	R513	A7	R528	D6	R544	C7	R713	B2	R731	C5	R901	A3	ZD901	A3
Q704	B4	R310	D2	R406	C6	R424	C7	R443	C6	R5010	B8	R514	A7	R529	D6	R545	C7	R714	B3	R734	C8	R902	A3	ZD902	A4
Q705	B3	R311	D2	R407	C6	R425	C7	R444	C6	R5011	B6	R515	A7	R530	D5	R546	C8	R716	C3	R735	C8	R904	A3	ZD903	A4
Q706	B3	R312	D2	R408	C6	R426	C7	R450	D7	R5013	B6	R516	A7	R531	D5	R701	B1	R717	C3	R736	B4	R905	A3		
Q707	B3	R313	D2	R409	C6	R427	B7	R473	C8	R5014	B6	R517	A6	R532	D6	R702	C2	R719	C3	R737	B4	R906	A4		
Q708	B5	R314	D2	R410	C6	R429	C8	R474	C8	R502	A5	R518	A6	R534	D6	R703	C2	R720	C3	R738	B4	R907	A3		
Q709	B5	R315	D4	R411	C6	R430	C8	R5001	B6	R503	D5	R519	A6	R535	D6	R704	C2	R721	B3	R739	B4	R908	B3		
Q901	A3	R316	D4	R412	C6	R431	C8	R5002	B6	R504	A5	R520	A6	R536	D6	R705	C3	R722	B2	R740	B4	RB703	C1		
Q902	A4	R317	D4	R413	C6	R432	C8	R5003	B7	R506	A6	R521	A6	R537	D6	R706	C3	R724	C4	R741	A5	RB904	B1		
R301	D1	R318	D3	R415	C6	R433	C8	R5004	B7	R507	A6	R522	A6	R538	D6	R707	C3	R725	C4	R742	B3	T701	B2		
R302	D1	R319	D4	R416	C7	R435	C8	R5005	B7	R508	A6	R523	D5	R539	D6	R708	C3	R726	C4	R743	B3	ZD301	D3		

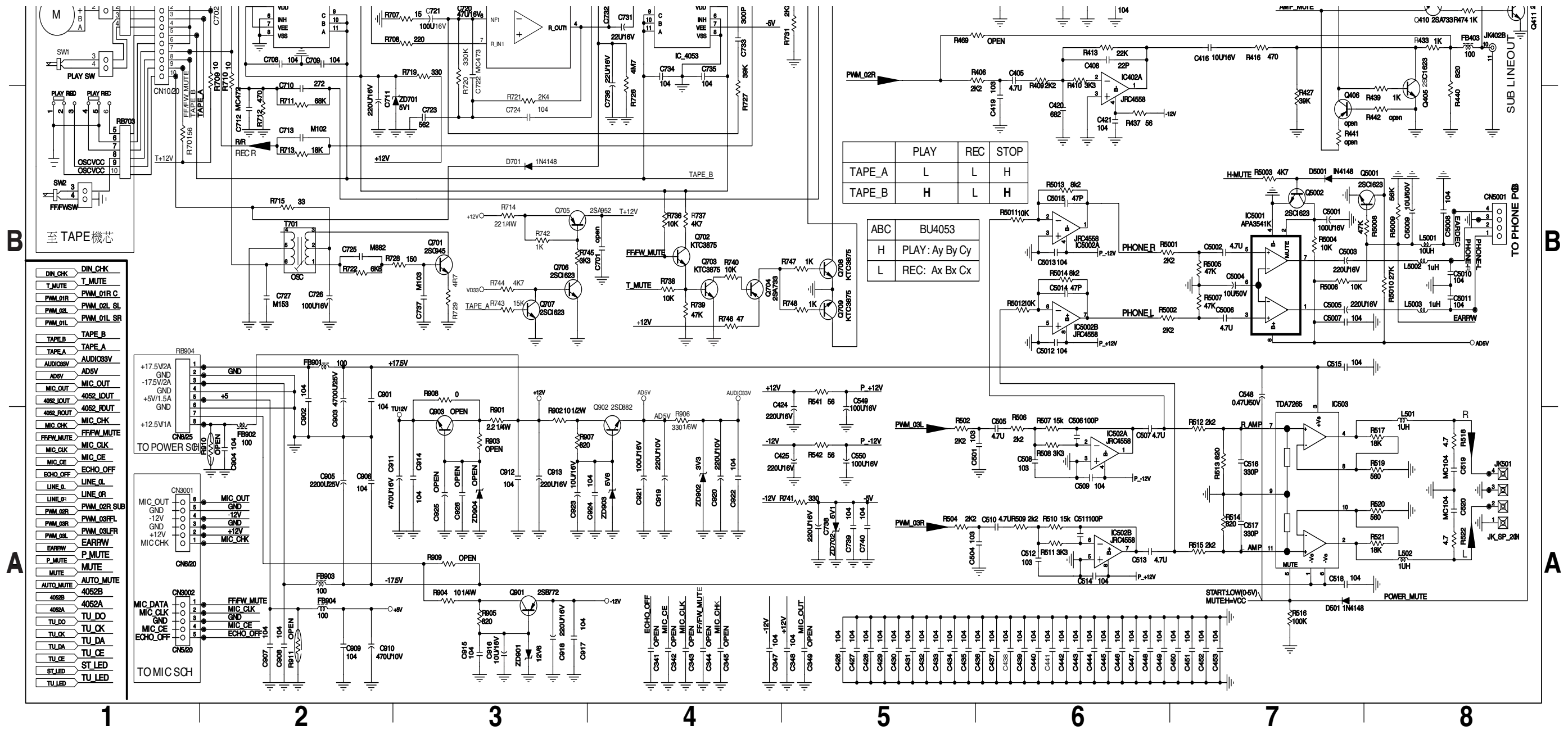

PCB LAYOUT MAIN (BOTTOM) VIEW

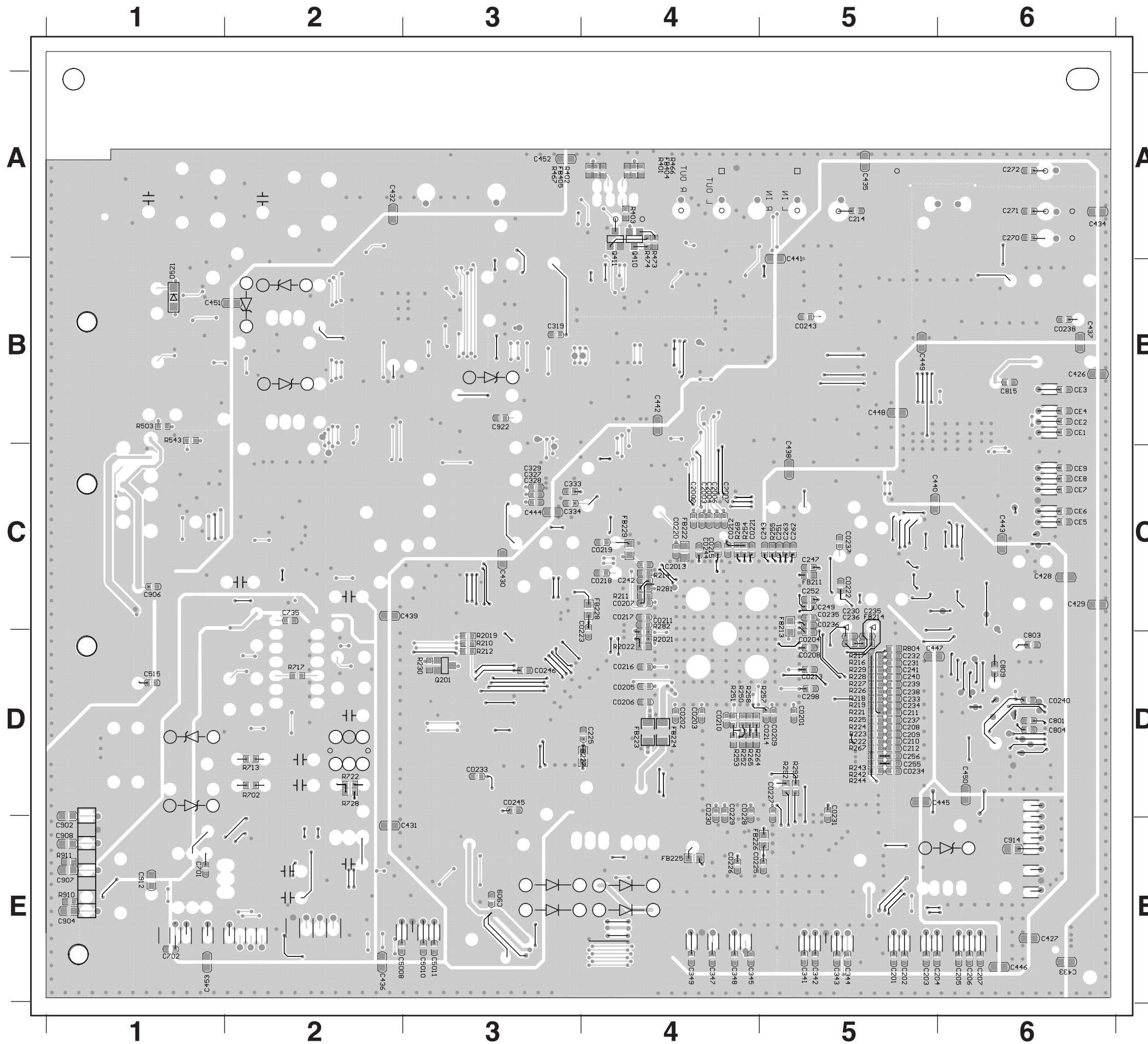

C0201	D5	C263	C5	FB228	C4
C0202	D4	C270	A6	FB229	C4
C0203	D4	C271	A6	Q201	D3
C0204	D5	C272	A6	Q410	A4
C0205	D4	C298	D5	Q411	A4
C0206	D4	C319	B3	R2019	D3
C0207	C4	C327	C3	R2022	D4
C0208	D5	C328	C3	R210	D3
C0209	D5	C329	C3	R212	D3
C0210	D4	C333	C3	R214	C4
C0211	C4	C334	C3	R216	D5
C0212	C4	C347	E4	R217	D5
C0213	D5	C348	E4	R218	D5
C0214	D5	C426	B6	R219	D5
C0215	C4	C427	E6	R221	D5
C0216	D4	C428	C6	R222	D5
C0217	C4	C429	C6	R223	D5
C0218	C4	C430	C3	R225	D5
C0219	C4	C431	E2	R226	D5
C0220	C4	C432	A2	R227	D5
C0221	C4	C433	E6	R228	D5
C0223	C4	C434	A6	R229	D5
C0225	E5	C435	A5	R230	D3
C0227	D5	C436	E2	R242	D5
C0228	D4	C437	B6	R243	D5
C0229	D4	C438	C5	R244	D5
C0230	D4	C439	C2	R250	D4
C0231	D5	C440	C6	R251	D4
C0233	D3	C441	B5	R252	D4
C0234	D5	C442	B4	R253	D4
C0235	D5	C443	C6	R254	C4
C0236	D5	C444	C3	R255	C5
C0237	C5	C445	D5	R257	D5
C0238	B6	C446	E6	R258	D4
C0240	D6	C447	D5	R264	D4
C0243	B5	C448	C5	R265	D4
C0244	C4	C449	B5	R267	D5
C0245	D3	C450	D6	R268	C4
C0246	D3	C451	B2	R281	C4
C2002	C4	C452	A3	R282	C4
C2003	C4	C453	E1	R292	D5
C2004	C4	C5008	E2	R473	A4
C2006	C4	C5010	E3	R474	A4
C2007	C4	C5011	E3	R503	B1
C201	E5	C515	D1	R543	B1
C2013	C4	C702	E1	R702	D2
C202	E5	C735	C2	R713	D2
C203	E5	C801	D6	R717	D2
C204	E5	C803	D6	R722	D2
C205	E6	C804	D6	R728	D2
C206	E6	C809	D6		
C207	E6	C815	B6		
C208	D5	C902	E1		
C209	D5	C904	E1		
C210	D5	C906	C1		
C211	D5	C907	E1		
C212	D5	C908	E1		
C214	A5	C909	E3		
C225	D4	C912	E1		
C230	D5	C914	E6		
C231	D5	C922	B3		
C232	D5	CE1	B6		
C233	D5	CE2	B6		
C234	D5	CE3	B6		
C235	D5	CE4	B6		
C236	D5	CE5	C6		
C237	D5	CE6	C6		
C238	D5	CE7	C6		
C239	D5	CE8	C6		
C240	D5	CE9	C6		
C241	D5	D521	B1		
C242	C4	FB211	C5		
C243	C5	FB213	C5		
C247	C5	FB214	D5		
C249	D5	FB222	C4		
C251	C5	FB223	D4		
C252	C5	FB224	D4		
C255	D5	FB225	E4		
C256	D5	FB226	E5		
C262	C5	FB227	D4		

ELECTRICAL PARTS LIST - MAIN BOARD

D201	9940 000 05203	DIODE UF4007	JK203	9940 000 00857	RCA JACK 3P R-B-G
D202	9940 000 05203	DIODE UF4007	JK401	9940 000 00859	RCA JACK 4P AUDIO IN
D203	9940 000 05203	DIODE UF4007	JK402	9940 000 05202	RCA JACK 1P BLK
D204	9940 000 05203	DIODE UF4007	JK501	9940 000 00862	SPK JACK 4P R-W-B-B
D5001	4822 130 83338	LL4148	L501	9965 000 20655	RF COIL 1μH
D501	4822 130 83338	LL4148	L502	9965 000 20655	RF COIL 1μH
D502	4822 130 83338	LL4148	Q201	9940 000 00915	XISTR NPN 2SC1623
D503	4822 130 83338	LL4148	Q202	9965 000 26939	XISTR PNP 2SA952
D504	4822 130 83338	LL4148	Q203	9965 000 26946	XISTR PNP 2SB772P/Q
D505	4822 130 83338	LL4148	Q401	9965 000 13683	TRANSISTOR KTC3875Y-RTK
D506	4822 130 83338	LL4148	Q402	9940 000 00921	XISTR PNP 2SA812
D507	4822 130 83338	LL4148	Q403	9965 000 13683	TRANSISTOR KTC3875Y-RTK
D508	4822 130 83338	LL4148	Q404	9965 000 13683	TRANSISTOR KTC3875Y-RTK
D509	4822 130 83338	LL4148	Q405	9940 000 00915	XISTR NPN 2SC1623
D510	4822 130 83338	LL4148	Q410	9940 000 00921	XISTR PNP 2SA812
D511	4822 130 83338	LL4148	Q411	9940 000 00915	XISTR NPN 2SC1623
D512	4822 130 83338	LL4148	Q5001	9940 000 00915	XISTR NPN 2SC1623
D513	4822 130 83338	LL4148	Q5002	9940 000 00915	XISTR NPN 2SC1623
D701	4822 130 83338	LL4148	Q501	9940 000 00915	XISTR NPN 2SC1623
D801	4822 130 83338	LL4148	Q502	9965 000 13683	TRANSISTOR KTC3875Y-RTK
D802	4822 130 83338	LL4148	Q503	9965 000 13683	TRANSISTOR KTC3875Y-RTK
D803	4822 130 83338	LL4148	Q504	9965 000 13683	TRANSISTOR KTC3875Y-RTK
D804	4822 130 83338	LL4148	Q505	9940 000 00921	XISTR PNP 2SA812
IC201	9940 000 05207	IC 208P ES8380FAA	Q506	9965 000 13683	TRANSISTOR KTC3875Y-RTK
IC202	9940 000 00831	IC 54P K4S641632H-UC	Q701	4822 130 41198	2SC945P
IC203	9965 000 26936	IC 48P MX26LV800 /55/98/51/68	Q702	9965 000 13683	TRANSISTOR KTC3875Y-RTK
IC203	9965 000 40983	IC 48P MX26LV800 /79	Q703	9965 000 13683	TRANSISTOR KTC3875Y-RTK
IC204	9940 000 05208	IC 8P TU24C02CS2BF	Q704	9940 000 00921	XISTR PNP 2SA812
IC205	9940 000 05209	IC 3P AZ809NSTR-E1	Q705	9965 000 26939	XISTR PNP 2SA952
IC206	9940 000 05211	IC 20P 74HC374	Q706	9940 000 00915	XISTR NPN 2SC1623
IC207	9965 000 23948	IC 14P 74HCU04D	Q707	9940 000 00915	XISTR NPN 2SC1623
IC209	9940 000 00839	IC 16PIN 74F138D	Q708	9965 000 13683	TRANSISTOR KTC3875Y-RTK
IC210	9940 000 00838	IC 20PIN 74F244	Q709	9965 000 13683	TRANSISTOR KTC3875Y-RTK
IC301	9965 000 29611	IC 8P CO4558A	Q801	9940 000 05228	MOSFET 2SK3018 30V/0.1A
IC302	9940 000 00841	IC 16P TC4052BFN	Q802	9940 000 05228	MOSFET 2SK3018 30V/0.1A
IC303	9940 000 05212	IC 16P CS5340-CZ	Q803	9965 000 26928	XISTR NPN 2SC2812N
IC401	9965 000 29611	IC 8P CO4558A	Q804	9965 000 26928	XISTR NPN 2SC2812N
IC402	9965 000 29611	IC 8P CO4558A	Q805	9965 000 26927	XISTR PNP 2SB1132RT100
IC5001	9965 000 26923	IC 8P APA3541-TRL	Q806	9965 000 26927	XISTR PNP 2SB1132RT100
IC5002	9965 000 29611	IC 8P CO4558A	Q901	9965 000 26946	XISTR PNP 2SB772P/Q
IC502	9965 000 29611	IC 8P CO4558A	Q902	9965 000 28742	XISTR NPN 2SD882P
IC503	9965 000 15892	IC TDA7265	RA202	9940 000 05229	RES ARRAY 100Ω 1/16W 5%
IC701	9965 000 29612	IC 16PIN TC4053BFN	RA203	9940 000 05231	RES ARRAY 33Ω 1/16W 5%
IC702	9940 000 05213	IC 14P AN7312 MEI	RA204	9940 000 05231	RES.ARRAY 33Ω 1/16W 5%
IC703	9965 000 29612	IC 16PIN TC4053BFN	RA205	9940 000 05229	RES.ARRAY 100Ω 1/16W 5%
IC801	9940 000 05214	IC 28P V5888S	RA206	9940 000 05229	RES.ARRAY 100Ω 1/16W 5%
JK201	9965 000 17363	RCA JACK 1P W/GND P	RA207	9940 000 05229	RES.ARRAY 100Ω 1/16W 5%
JK202	9965 000 23599	RCA+DIN JK 1RCA+4P DIN	T701	9940 000 00866	OSC COIL REC 3MH

ELECTRICAL PARTS LIST - MAIN BOARD

XL201	9940 000 05201	X'TAL 27MHZ H3.5MM
ZD201	9965 000 26931	ZENER 7.5V 0.05 0.5W (F1)
ZD202	9965 000 26931	ZENER 7.5V 0.05 0.5W (F1)
ZD203	9965 000 26931	ZENER 7.5V 0.05 0.5W (F1)
ZD204	9965 000 26931	ZENER 7.5V 0.05 0.5W (F1)
ZD205	9965 000 26931	ZENER 7.5V 0.05 0.5W (F1)
ZD206	9965 000 26931	ZENER 7.5V 0.05 0.5W (F1)
ZD207	9965 000 26931	ZENER 7.5V 0.05 0.5W (F1)
ZD208	9965 000 26931	ZENER 7.5V 0.05 0.5W (F1)
ZD209	9965 000 26931	ZENER 7.5V 0.05 0.5W (F1)
ZD210	9965 000 26931	ZENER 7.5V 0.05 0.5W (F1)
ZD211	9965 000 26931	ZENER 7.5V 0.05 0.5W (F1)
ZD212	9965 000 26931	ZENER 7.5V 0.05 0.5W (F1)
ZD301	9965 000 26930	ZENER 5.6V 0.05 0.5W (E2)
ZD302	9965 000 26930	ZENER 5.6V 0.05 0.5W (E2)
ZD701	9965 000 26942	DIODE ZENR 5.0-5.2V 0.5W
ZD702	9965 000 26942	DIODE ZENR 5.0-5.2V 0.5W
ZD901	9940 000 05204	DIODE ZENR 12.6-13.1V 0.5W
ZD902	9940 000 05205	DIODE ZENR 3.2-3.4V 0.5W
ZD903	9940 000 05206	DIODE ZENR 5.6-5.9V 0.5W

Note: Only these parts mentioned in the list are normal service parts.

TUNER ADJUSTMENT TABLE

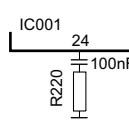
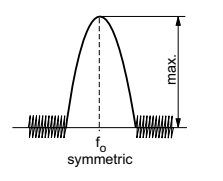
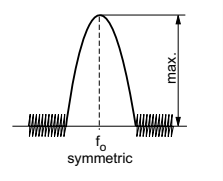
Waverange	Input frequency	Input	Tuned to	Adjust	Output	Scope/Voltmeter
<i>VARICAP ALIGNMENT</i>						
FM 87.5 - 108MHz (50kHz grid)			108MHz	check		7.5V ±1V
			87.5MHz	check		1.4V ±0.2V
MW 531-1602kHz (9kHz grid) 530-1700kHz (10kHz grid) (98/ 55/ 51)			1602KHz	check		7.2V ±1V
			531KHz	T005		1.1V ±0.2V
			1700KHz	check		7.2V ±1V
			531KHz	T005		1.1V ±0.2V
<i>FM - RF</i>						
FM	108MHz		106MHz	VC001	MAX	MAX
	87.5MHz	mod=1kHz Δf=±22.5kHz	90.1MHz	L001		
<i>AM IF</i>						
AM	450kHz	Connect pin 6 of IC001 (AM Osc.) with short wire to ground (pin 4)		T001 T002	MAX	
<i>AM AFC</i> MW				ΔV=mV		
<i>AM RF 3)</i>						
MW	1404kHz		1404kHz	VC001	MAX	
	612kHz		612kHz	T006		
	1000kHz		1000kHz	VC001		
	600kHz		600kHz	T006		

TUNER BOARD

TABLE OF CONTENTS

Tuner Adjustment Table 7-1
 Circuit Diagram (/51 ver.) 7-2
 Circuit Diagram (/98 & /55 ver.) 7-3
 PCB Layout (/51 ver.) 7-4
 PCB Layout (/98 & /55 ver.) 7-5

Remark: The module is not intend to be repaired on component level. Circuit Diagrams and Printed Board drawings are published for orientation only. The whole Tuner Board Ass'y can be orderd with 12nc: 9940 000 05309 for /55/98 and 9940 000 05714 for /51.

Use Service Testprogram. By selecting the TUNER TEST test frequencies will be stored as preset frequencies automatically.

1) If sensitivity of frequency counter is too low adjust to max. channel separation (input signal: stereo left 90% + 9%, adjust output on right channel to minimum)

2) RC network serves for damping the IF-filter while adjusting the other one.

3) For AM RF adjustments the original frame antenna has to be used!

CIRCUIT DIAGRAM : TUNER BOARD (/ 51 ver.)

ANT001	A1	C01	C2	C020	B2	C030	D1	C039	D2	C047	D1	D001	A1	IF002	C1	R002	A1	R010	A2	R018	C2	R028	C2	T001	B1	VD002	A2
C002	A1	C011	A2	C021	B2	C031	B2	C040	C2	C048	D1	D002	A1	IF003	B2	R003	A1	R011	A2	R019	C2	R029	C2	T002	C1	VR001	B2
C004	A1	C012	B2	C022	D2	C032	B1	C041	C2	C049	A2	D003	C1	L1	A1	R004	B1	R012	B2	R020	D2	R030	C1	T003	C1	XL1	C2
C005	B1	C015	A2	C023	D2	C034	C2	C042	C2	C050	B2	D004	C2	Q001	B1	R005	B1	R013	A2	R021	D2	R033	C1	T004	A2		
C006	B1	C016	A2	C025	B2	C035	A2	C043	C2	C071	B2	D005	A2	Q002	C1	R006	B1	R014	B2	R023	C2	R036	A1	T005	A2		
C007	B1	C017	B2	C026	B2	C036	D2	C044	C2	C1	C2	EF450-G1	A1	Q003	C2	R007	A1	R015	B2	R025	B2	R037	A1	T006	B2		
C008	B1	C018	B2	C029	B2	C037	B2	C045	C1	CN001	D2	IC001	B1	Q004	A2	R008	B1	R016	C1	R026	B2	R040	A1	VC001	A2		
C009	A2	C019	B1	C03	C2	C038	C2	C046	C1	CN002	A2	IF001	B1	R001	B1	R009	A1	R017	B2	R027	C2	R046	B1	VD001	A2		

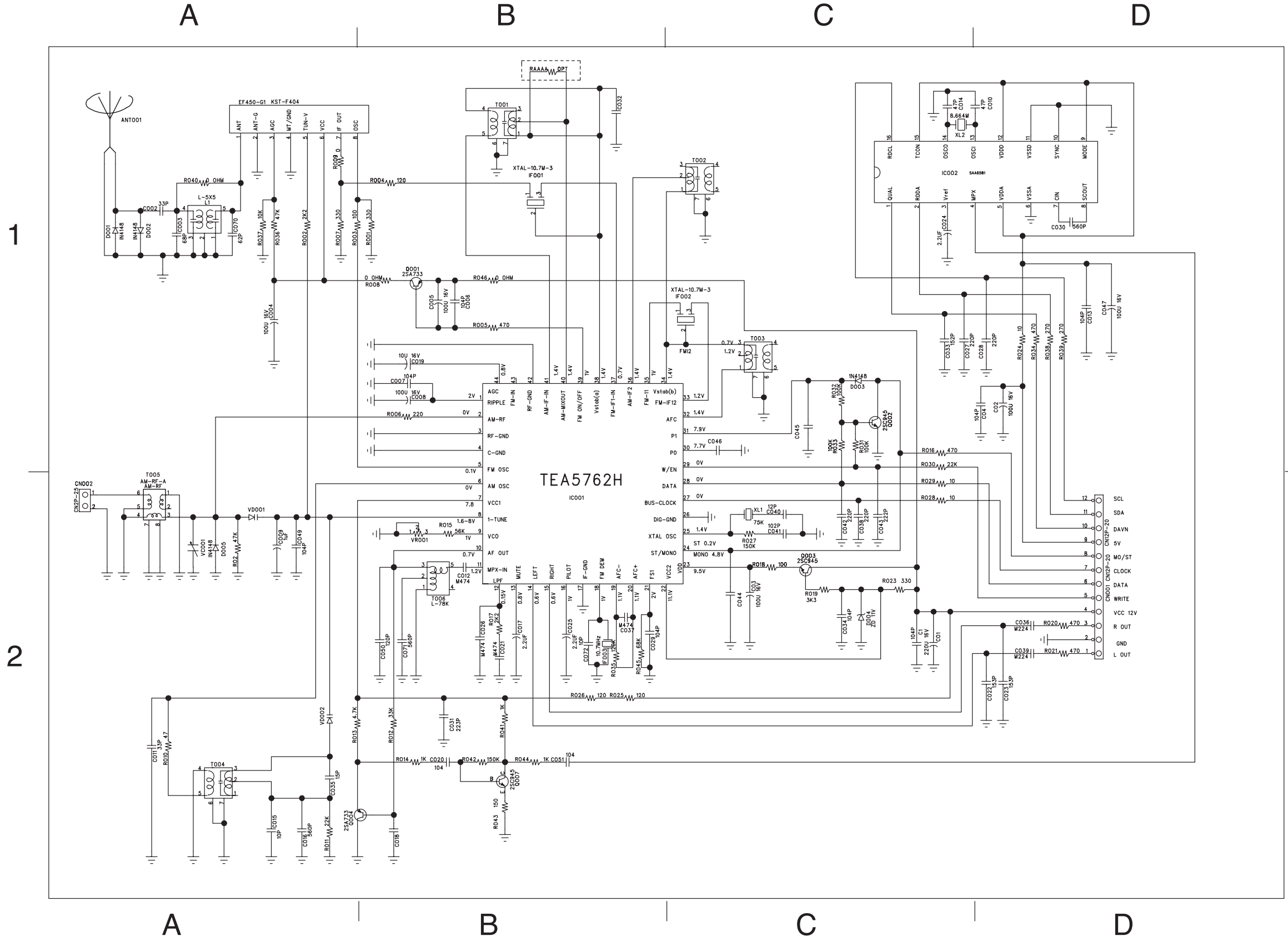

1

2

1

2

CIRCUIT DIAGRAM : TUNER BOARD (/55 & /98 ver.)

ANT001	A1	C011	A2	C022	C2	C033	D1	C043	D1	D004	C2	Q003	B1	R016	D2	R027	D1	VC001	B1
C002	A1	C012	B2	C023	C2	C034	C2	C044	D2	D005	A2	Q004	B2	R017	C2	R028	E1	VC002	A2
C004	E2	C013	B2	C024	C2	C035	B1	C047	B1	IC001	C1	R001	B1	R018	D2	R029	E1	VD001	B1
C005	B1	C014	B2	C025	C2	C036	E2	C048	B1	IF001	D1	R002	B1	R019	D2	R030	E1	VD002	B1
C006	B1	C015	A2	C026	B2	C037	C2	C050	B1	IF002	C1	R004	B1	R020	E2	R034	E1	VD003	A1
C007	B1	C016	B2	C029	C2	C038	E1	CN001	E2	IF003	C2	R005	B1	R021	E2	T001	C1	VD004	B2
C008	B1	C019	B1	C03	B1	C039	E2	CN002	A1	L02	A1	R006	B1	R023	D1	T002	D1	VR001	B1
C009	B1	C02	D2	C030	D2	C040	D2	D001	A1	L001	B1	R010	A2	R024	B1	T003	D1	XL1	D2
C01	D2	C020	D1	C031	B2	C041	D1	D002	A1	Q001	D2	R011	B2	R025	C2	T005	A2		
C010	B2	C021	C2	C032	D1	C042	D1	D003	E1	Q002	E1	R015	B1	R026	C2	T006	A1		

1

1

2

2

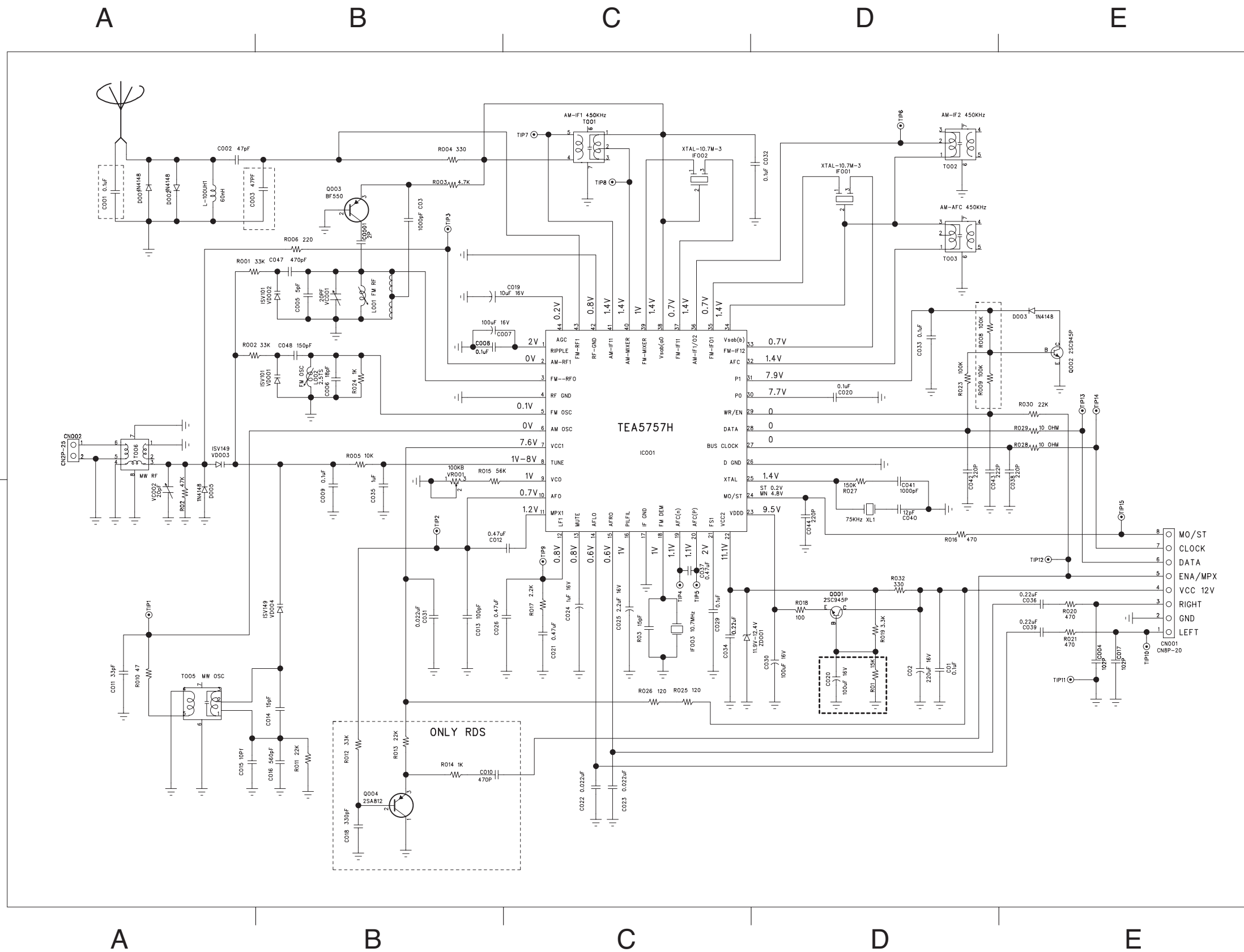

A

B

C

D

E

PCB LAYOUT - TUNER BOARD (TOP VIEW) - /51ver.

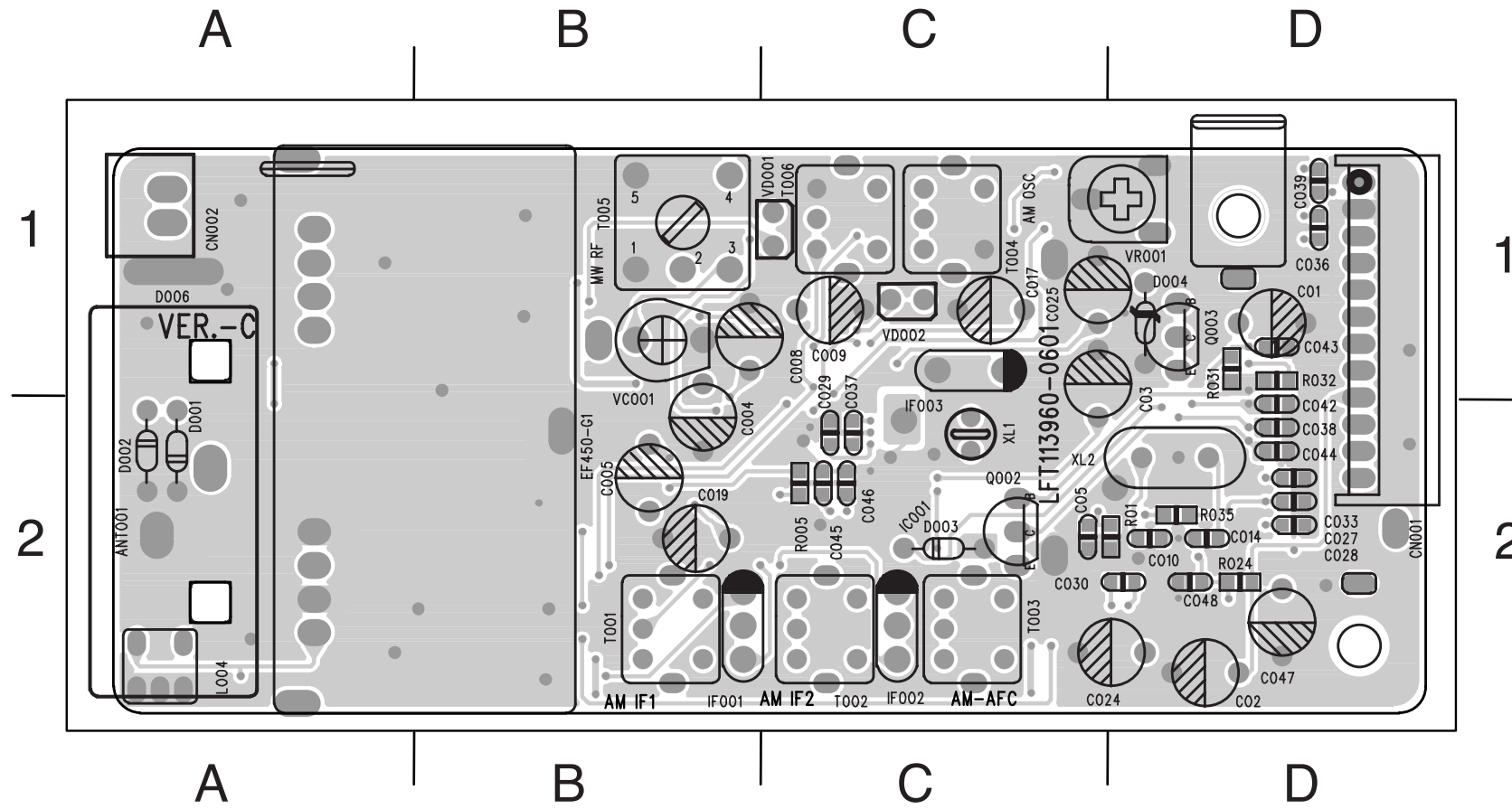

ANT001	A2	CN002	A1
C004	B2	D001	A2
C005	B2	D002	A2
C008	B1	D003	C2
C009	C1	D004	D1
C010	D2	D005	A1
C017	C1	EF450-G1	B2
C019	B2	IC001	C2
C02	D2	IF001	B2
C025	C1	IF002	C2
C029	C2	IF003	C1
C03	C1	L004	A2
C030	C2	Q002	C2
C036	D1	Q003	D1
C037	C2	R005	C2
C038	D2	T001	B2
C039	D1	T002	C2
C042	D1	T003	C2
C043	D1	T003	C2
C044	D2	T005	B1
C045	C2	T006	C1
C046	C2	VC001	B1
C047	D2	VD001	C1
C048	D2	VD002	C1
CN001	D1	VR001	D1
		XL1	C2

PCB LAYOUT - TUNER BOARD(BOTTOM VIEW) - /51 ver.

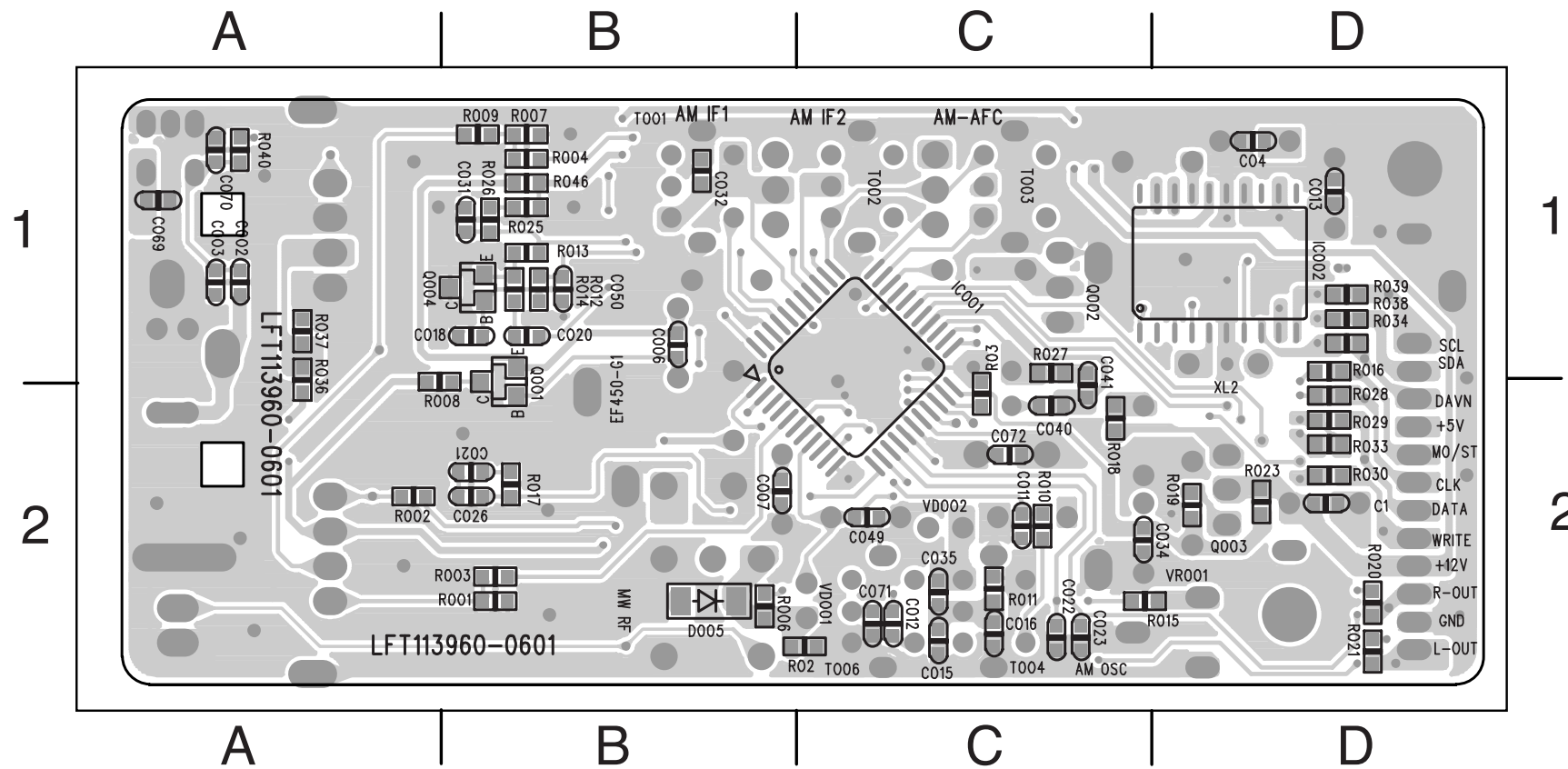

C002	A1	R008	B1
C006	B1	R009	B1
C007	B2	R010	C2
C011	C2	R011	C2
C012	C2	R012	B1
C015	C2	R013	B1
C016	C2	R014	B1
C018	B1	R015	C2
C020	B1	R016	D1
C021	B2	R017	B2
C022	C2	R018	C2
C023	C2	R019	D2
C026	B2	R020	D2
C031	B1	R021	D2
C032	B1	R023	D2
C034	C2	R025	B1
C035	C2	R026	B1
C040	C2	R027	C1
C041	C1	R028	D2
C049	C2	R029	D2
C050	B1	R03	C2
C071	C2	R030	D2
C1	D2	R033	D2
D005	B2	R036	A1
IC001	C1	R039	D1
Q001	B1	R040	A1
Q002	C1	R046	B1
Q003	D2	T002	C1
Q004	B1	T003	C1
R001	B2	T004	C2
R002	A2	VD001	C2
R003	B2	VD002	C2
R004	B1	VR001	D2
R006	B2	XL2	D2
R007	B1		

PCB LAYOUT - TUNER BOARD (TOP VIEW) - /55 & /98ver.

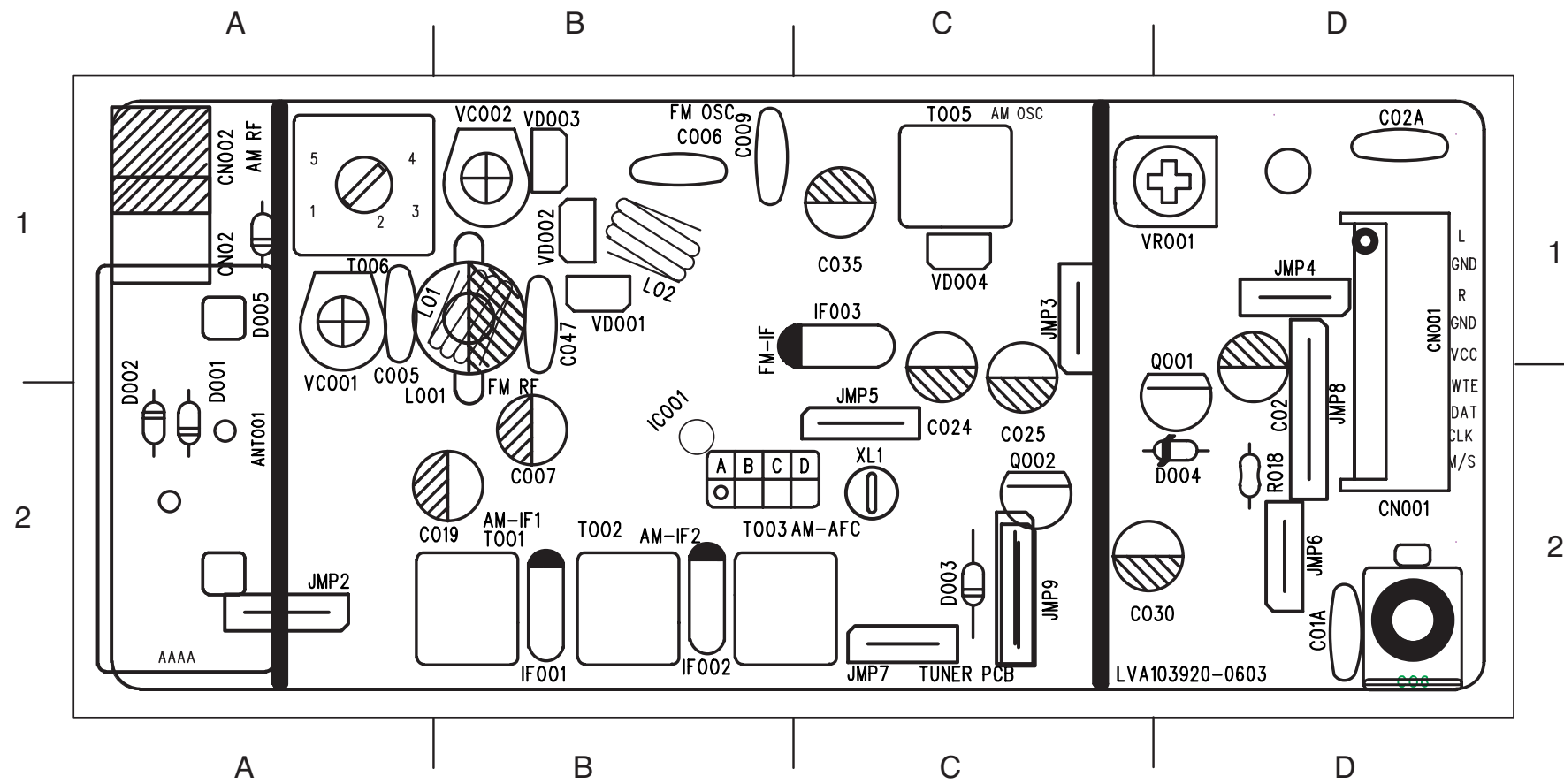

ANT001	A2	JMP4	D1
C005	A1	JMP5	C2
C006	B1	JMP6	D2
C007	B2	JMP7	C2
C009	B1	JMP8	D2
C01	D2	JMP9	C2
C019	B2	L001	B1
C024	C2	L02	B1
C025	C2	Q001	D2
C030	D2	Q002	C2
C035	C1	R018	D2
C047	B1	T001	B2
CN001	D1	T002	B2
CN002	A1	T003	B2
D001	A2	T005	C1
D002	A2	T006	A1
D003	C2	VC001	A1
D004	D2	VC002	B1
D005	A1	VD001	B1
IF001	B2	VD002	B1
IF002	B2	VD003	B1
IF003	C1	VD004	C1
JMP2	A2	VR001	D1
JMP3	C1	XL1	C2

PCB LAYOUT - TUNER BOARD (BOTTOM VIEW) - /55 & /98 ver.

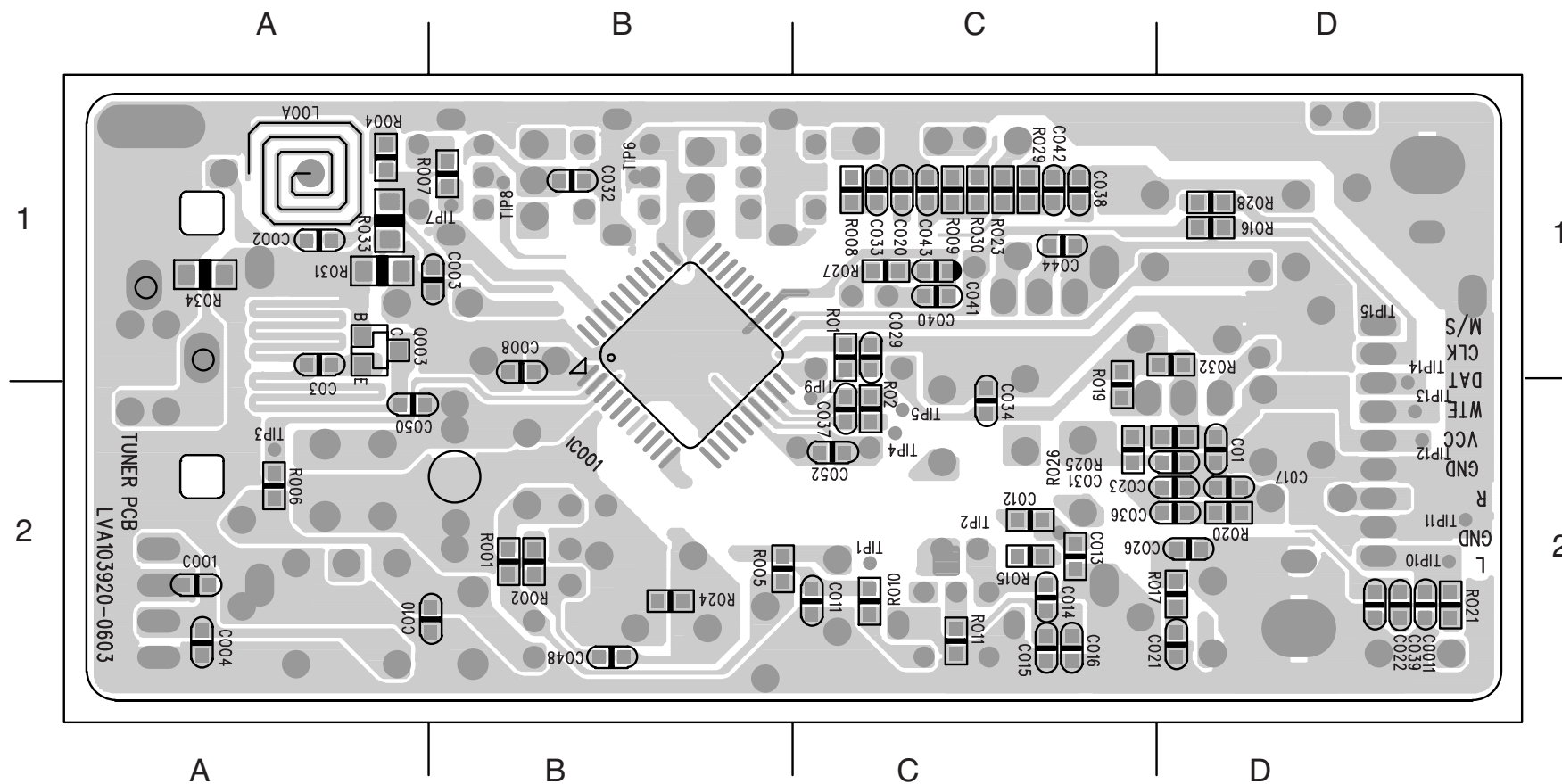

C002	A1	C050	A2
C004	A2	C052	C2
C008	B1	IC001	B1
C010	A2	Q003	A1
C011	D2	R001	B2
C012	C2	R002	B2
C013	C2	R004	A1
C014	C2	R005	B2
C015	C2	R006	A2
C016	C2	R007	B1
C020	C1	R010	C2
C021	D2	R011	C2
C022	D2	R015	C2
C023	D2	R016	D1
C026	D2	R017	D2
C029	C1	R019	C2
C03	A1	R020	D2
C031	C2	R021	D2
C032	B1	R023	C1
C033	C1	R024	B2
C034	C2	R025	C2
C036	D2	R026	C2
C037	C2	R027	C1
C038	C1	R028	D1
C039	D2	R029	C1
C040	C1	R030	C1
C041	C1	R031	A1
C042	C1	R032	D1
C043	C1	R033	A1
C044	C1	R034	A1
C048	B2		

POWER BOARD

TABLE OF CONTENTS

Voltage 8-1
 Circuit Diagram 8-2
 PCB Layout 8-3
 Electrical Parts List 8-4

VOLTAGE

IC901 UC3843AL								
Pin NO	1	2	3	4	5	6	7	8
Voltage	2.25	0.00	0.33	1.90	0.00	0.73	11.71	4.90

IC902 CTR:200-400								
Pin NO	1	2	3	4				
Voltage	4.90	2.00	0.00	3.80				

IC903 TL431 TO-92								
Pin NO	1	2	3					
Voltage	3.86	0.00	2.49					

IC904 CTR:200-400								
Pin NO	1	2	3	4				
Voltage	1.18	0.00	0.00	0.00				

Q901 FQPF7N65C			
Pin NO	1	2	3
Voltage	0.00	2.97	0.00

Q905 2SC945P			
Pin NO	1	2	3
Voltage	0.00	1.90	0.00

Q902 STP16NF06			
Pin NO	1	2	3
Voltage	11.67	5.12	5.14

Q906 2SC945P			
Pin NO	1	2	3
Voltage	0.66	0.00	0.00

Q903 2SB772P/Q			
Pin NO	1	2	3
Voltage	12.86	12.86	12.13

Q907 2SC2001L			
Pin NO	1	2	3
Voltage	0.00	5.02	0.00

Q904 2SC945P			
Pin NO	1	2	3
Voltage	0.72	0.06	0.00

Q908 2SC945P			
Pin NO	1	2	3
Voltage	0.73	0.00	0.00

Q909 2SC945P			
Pin NO	1	2	3
Voltage	0.66	0.00	0.00

Q911 2SA733Q			
Pin NO	1	2	3
Voltage	13.30	0.00	13.30

Q910 2SA733Q			
Pin NO	1	2	3
Voltage	5.00	0.00	2.56

Q912 2SC945P			
Pin NO	1	2	3
Voltage	5.00	0.00	13.30

CIRCUIT DIAGRAM-POWER BOARD

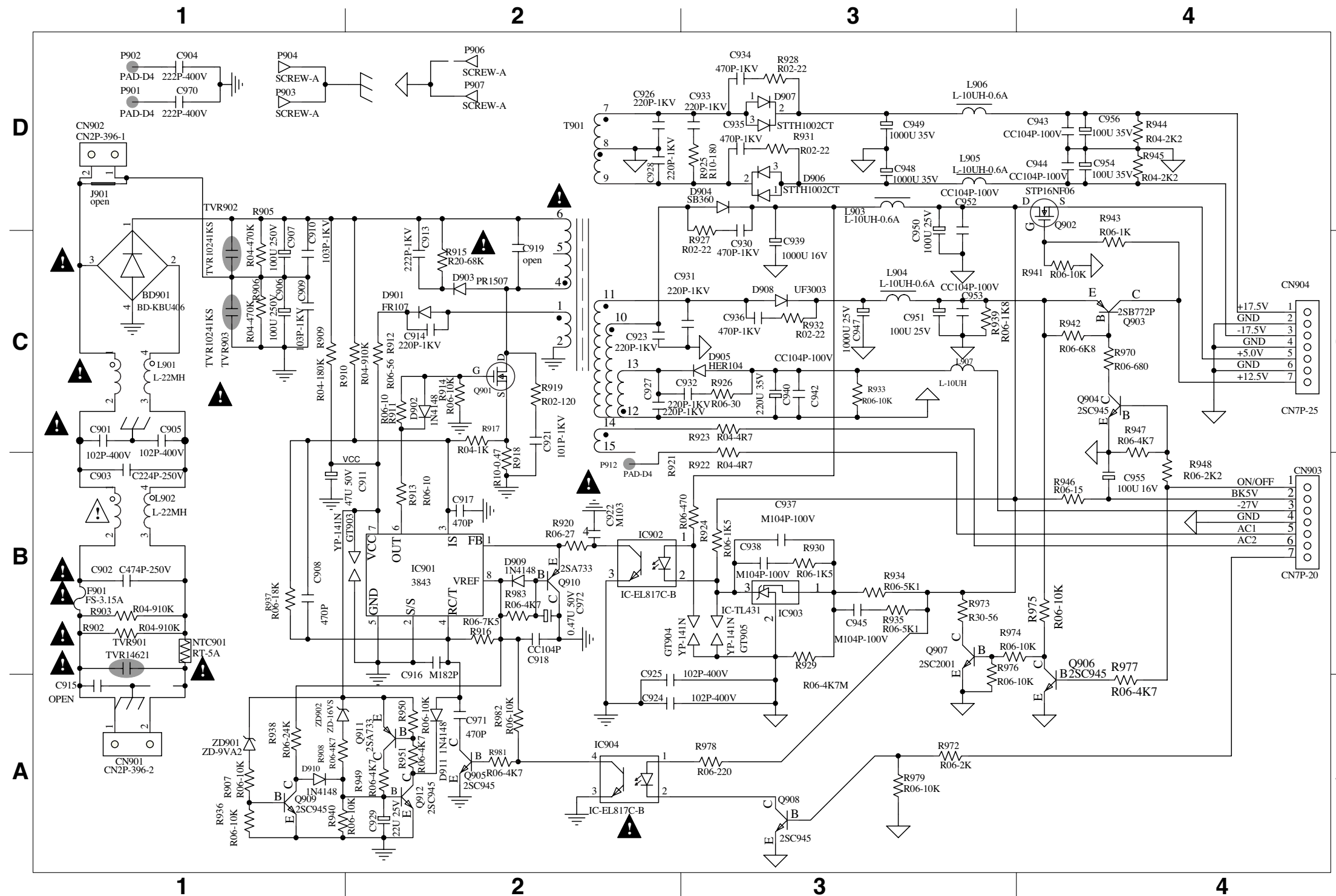

BD901	C1	CN903	B4	R917	C2
C901	C1	CN904	C4	R918	B2
C902	B1	D901	C2	R919	C2
C903	B1	D902	C2	R920	B2
C904	D1	D903	C2	R921	B3
C905	C1	D904	D3	R922	B3
C906	C1	D905	C3	R923	C3
C907	C1	D906	D3	R924	B3
C908	B1	D907	D3	R925	D3
C909	C1	D908	C3	R926	C3
C910	C1	D909	B2	R927	D3
C911	B1	D910	A1	R928	D3
C913	C2	D911	A2	R929	B3
C914	C2	F901	B1	R930	B3
C916	B2	GT903	B2	R931	D3
C917	B2	GT904	B3	R932	C3
C919	C2	GT905	B3	R933	C3
C921	C2	IC901	B2	R934	B3
C922	B2	IC902	B2	R935	B3
C923	C2	IC903	B3	R936	A1
C924	A2	IC904	A2	R938	A1
C925	A2	L901	C1	R939	C3
C926	D2	L902	B1	R940	A1
C927	C2	L903	D3	R941	C4
C928	D2	L904	C3	R942	C4
C929	A2	L905	D3	R943	C4
C930	D3	L906	D3	R944	D4
C931	C3	L907	C3	R945	D4
C932	C3	NTC901	B1	R946	B4
C933	D3	Q901	C2	R947	C4
C934	D3	Q902	D4	R948	B4
C935	D3	Q903	C4	R949	A2
C936	C3	Q904	C4	R950	A2
C937	B3	Q905	A2	R951	A2
C938	B3	Q906	A4	R970	C4
C939	C3	Q907	B3	R972	A3
C940	C3	Q908	A3	R973	B3
C942	C3	Q909	A1	R974	B3
C943	D4	Q910	B2	R975	B4
C944	D4	Q911	A2	R976	B3
C945	B3	Q912	A2	R977	A4
C947	C3	R902	B1	R978	A3
C948	D3	R903	B1	R979	A3
C949	D3	R905	C1	R981	A2
C950	D3	R906	C1	R982	A2
C952	D3	R907	A1	R983	B2
C953	C3	R908	A1	T901	D2
C954	D4	R909	C1	TVR901	B1
C955	B4	R910	C2	TVR902	C1
C956	D4	R911	C2	TVR903	C1
C970	D1	R912	C2	ZD901	A1
C971	A2	R913	B2	ZD902	A1
C972	B2	R914	C2		
CN901	A1	R915	C2		
CN902	D1	R916	B2		

PCB LAYOUT-POWER BOARD

BD901	B1	C913	B2	C928	B4	C940	A4	C955	A4	D904	B4	IC901	A2	J910	A4	L907	A4	Q906	A4	R908	A3	R920	A3	R932	B4	R945	B4	R982	A3
C901	B1	C914	A3	C929	A3	C942	A4	C956	B4	D905	A3	IC902	A3	J911	A4	NTC901	A1	Q907	A4	R909	A2	R921	A3	R933	A4	R951	A2	R983	A2
C902	A1	C916	A2	C930	B4	C943	B4	C970	A3	D906	B4	IC903	A4	J912	A4	R946	A4	Q908	A3	R910	A2	R922	A4	R934	A4	R970	A4	T901	B3
C903	B1	C917	A2	C931	A3	C944	B4	C971	A2	D907	B3	IC904	A3	J913	A4	R947	A4	Q909	A3	R911	A2	R923	A4	R935	A4	R972	A3	TVR901	A1
C904	B3	C919	B2	C932	A3	C945	A4	C972	A2	D908	A4	J902	B1	J914	A4	R948	A4	Q910	A2	R912	A3	R924	A3	R936	A3	R973	A4	TVR902	B2
C905	B1	C921	B2	C933	B4	C947	A4	CN901	A1	D909	A2	J903	A2	J915	B4	R949	A3	Q911	A3	R913	A2	R925	B4	R938	A3	R974	A4	TVR903	B2
C906	B2	C922	A3	C934	B3	C948	B4	CN902	B2	D910	A3	J904	A2	L901	B1	R950	A3	Q912	A3	R914	A2	R926	A4	R939	A4	R975	A4	ZD901	A3
C907	B2	C923	B4	C935	B4	C949	B3	CN903	A4	D911	A2	J905	A2	L902	A1	Q901	B2	R902	A1	R915	B2	R927	B4	R940	A3	R976	A4	ZD902	A3
C908	A2	C924	A3	C936	A4	C950	B4	CN904	B4	F901	A1	J906	B2	L903	B4	Q902	B4	R903	A1	R916	A2	R928	B3	R941	B4	R977	A4		
C909	B2	C925	B3	C937	A4	C952	B4	D901	A3	GT903	A2	J907	B2	L904	B4	Q903	A4	R905	B2	R917	A2	R929	A4	R942	A4	R978	A3		
C910	B2	C926	B3	C938	A3	C953	A4	D902	A2	GT904	A3	J908	A3	L905	B4	Q904	A4	R906	B2	R918	B2	R930	A3	R943	B4	R979	A3		
C911	A2	C927	A3	C939	B4	C954	B4	D903	B2	GT905	A3	J909	A3	L906	B4	Q905	A2	R907	A3	R919	B2	R931	B4	R944	B4	R981	A3		

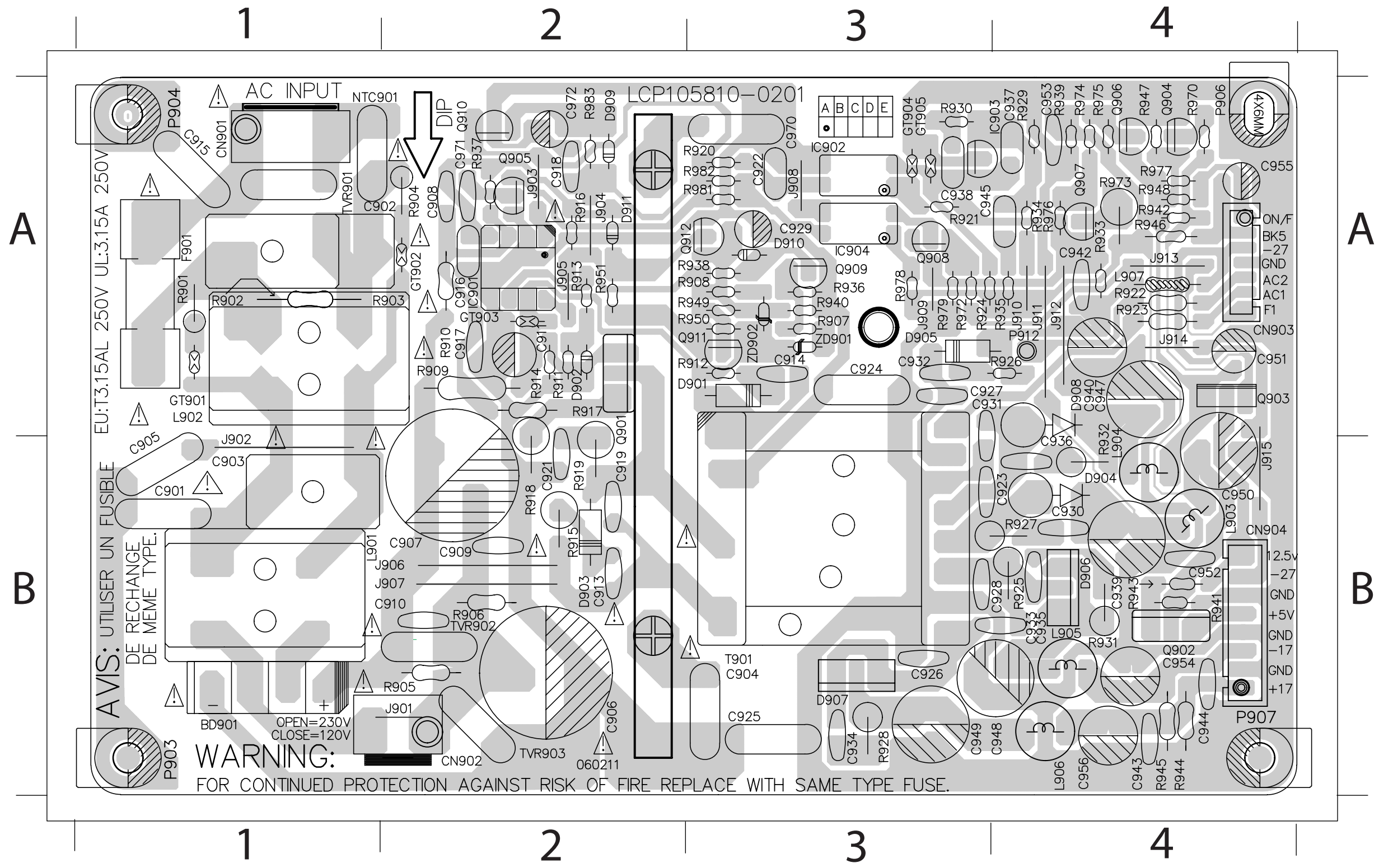

ELECTRICAL PARTS LIST - POWER BOARD

BD901	9940 000 02065	RECTIFIER GBU4J 4A 600V	L904	9965 000 16694	6μH 13.5TS 2UEW
C901	△ 9965 000 27115	CAP. SAFTY 102PF 250V 20%	L905	9965 000 16694	6μH 13.5TS 2UEW
C902	△ 9940 000 05238	CAP. SAFETY 0.47μF 300V 10%	L906	9965 000 16694	6μH 13.5TS 2UEW
C903	△ 9940 000 05237	CAP. SAFETY 0.22μF 300V 10%	L907	9965 000 15871	INDUCTOR 10μH 10%
C904	9965 000 27129	400V 0.0022μF P10MM 125' C	NTC901	9940 000 05232	THERMISTOR NTC 5Ω 5A
C905	△ 9965 000 27115	CAP. SAFTY 102PF 250V 20%	Q901	9940 000 05254	MOSFET STP6NK70Z 5A 700V
C909	9965 000 18042	COND DISC 0.01μF 1KV 20%	Q902	4822 130 11336	STP16NF06FP
C910	9965 000 18042	COND DISC 0.01μF 1KV 20%	Q903	9965 000 26946	XISTR PNP 2SB772P/Q
C913	9965 000 27125	COND DISC 0.0022μF 1KV 20%	Q904	4822 130 41198	2SC945P
C914	9940 000 05236	COND DISC 220PF 1KV 10%	Q905	4822 130 41198	2SC945P
C919	9940 000 05235	COND DISC 100PF 1KV 10%	Q906	4822 130 41198	2SC945P
C921	9940 000 05235	COND DISC 100PF 1KV 10%	Q907	4822 130 41651	2SC2001L
C923	9940 000 05236	COND DISC 220PF 1KV 10%	Q908	4822 130 41198	2SC945P
C924	△ 9965 000 27115	CAP. SAFTY 102PF 250V 20%	Q909	4822 130 41198	2SC945P
C925	△ 9965 000 27115	CAP. SAFTY 102PF 250V 20%	Q910	9965 000 28743	XISTR PNP 2SA733Q,P NEC
C926	9940 000 05236	COND DISC 220PF 1KV 10%	Q911	9965 000 28743	XISTR PNP 2SA733Q,P NEC
C927	9940 000 05236	COND DISC 220PF 1KV 10%	Q912	4822 130 41198	2SC945P
C928	9940 000 05236	COND DISC 220PF 1KV 10%	R918	9940 000 05245	RES. 0.39Ω 2W 5%
C930	9965 000 20264	COND DISC 470PF 1KV 10%	R919	9965 000 27133	RES. METAL 120Ω 3W 5%
C931	9940 000 05236	COND DISC 220PF 1KV 10%	R922	△ 9940 000 05246	FUSE RES. 2.7Ω 1/4W 5%
C932	9940 000 05236	COND DISC 220PF 1KV 10%	R923	△ 9940 000 05246	FUSE RES 2.7Ω 1/4W 5%
C933	9940 000 05236	COND DISC 220PF 1KV 10%	T901	△ 9940 000 05234	TRAFO ER-2834 6 8P 100W
C934	9965 000 20264	COND DISC 470PF 1KV 10%	TVR901	9965 000 32754	THERMIST 50A 561V
C935	9965 000 20264	COND DISC 470PF 1KV 10%	TVR902	9965 000 27114	VARISTOR TVR10
C936	9965 000 20264	COND DISC 470PF 1KV 10%	TVR903	9965 000 27114	VARISTOR TVR10
C970	9965 000 27129	400V 0.0022μF P10MM 125' C	ZD901	9940 000 05251	DIODE ZENR 7.8-8.4V 0.5W
D901	9940 000 01571	DIODE FR107 1A 1000V	ZD902	9940 000 02067	DIODE ZENR 14.5-15.1V 0.5W
D903	9940 000 00938	DIODE PR1507 1.5A 1000V			
D904	9940 000 05249	DIODE SB360 3A 60V			
D905	9940 000 00941	DIODE HER104 1A 300V 50NS			
D906	9940 000 05252	DIODE RECT. BYQ28E-200 10A			
D906	9940 000 05253	RECTIFIER UF1002CT 3P			
D907	9940 000 05252	DIODE RECT. BYQ28E-200 10A			
D907	9940 000 05253	RECTIFIER UF1002CT 3P			
D908	9940 000 00943	DIODE UF3003 3A 200V			
F901	△ 9965 000 17388	FUSE 3.15A 250V SLOW			
GT903	△ 9965 000 29310	ABSORBER 140V 500A L			
GT904	△ 9965 000 29310	ABSORBER 140V 500A L			
GT905	△ 9965 000 29310	ABSORBER 140V 500A L			
IC901	9940 000 05255	IC 8P UC3843AL			
IC902	9940 000 00946	OPTICAL SENSOR 4P			
IC903	9940 000 01572	IC 3P TL431			
IC904	9940 000 00946	OPTICAL SENSOR 4P			
L901	9940 000 05233	COMMON COIL 22MH			
L902	9940 000 05233	COMMON COIL 22MH			
L903	9965 000 16694	6μH 13.5TS 2UEW			

Note: Only these parts mentioned in the list are normal service parts.

DVD LOADER

It is not recommended for component repair on this Module but to replace the whole assembly when it becomes defective. Therefore limited service parts list is only for reference.

TABLE OF CONTENTS

Explorer View (DVD Loader).....	9-2
Mechanical Part list	9-3

Explorer View - DVD Loader

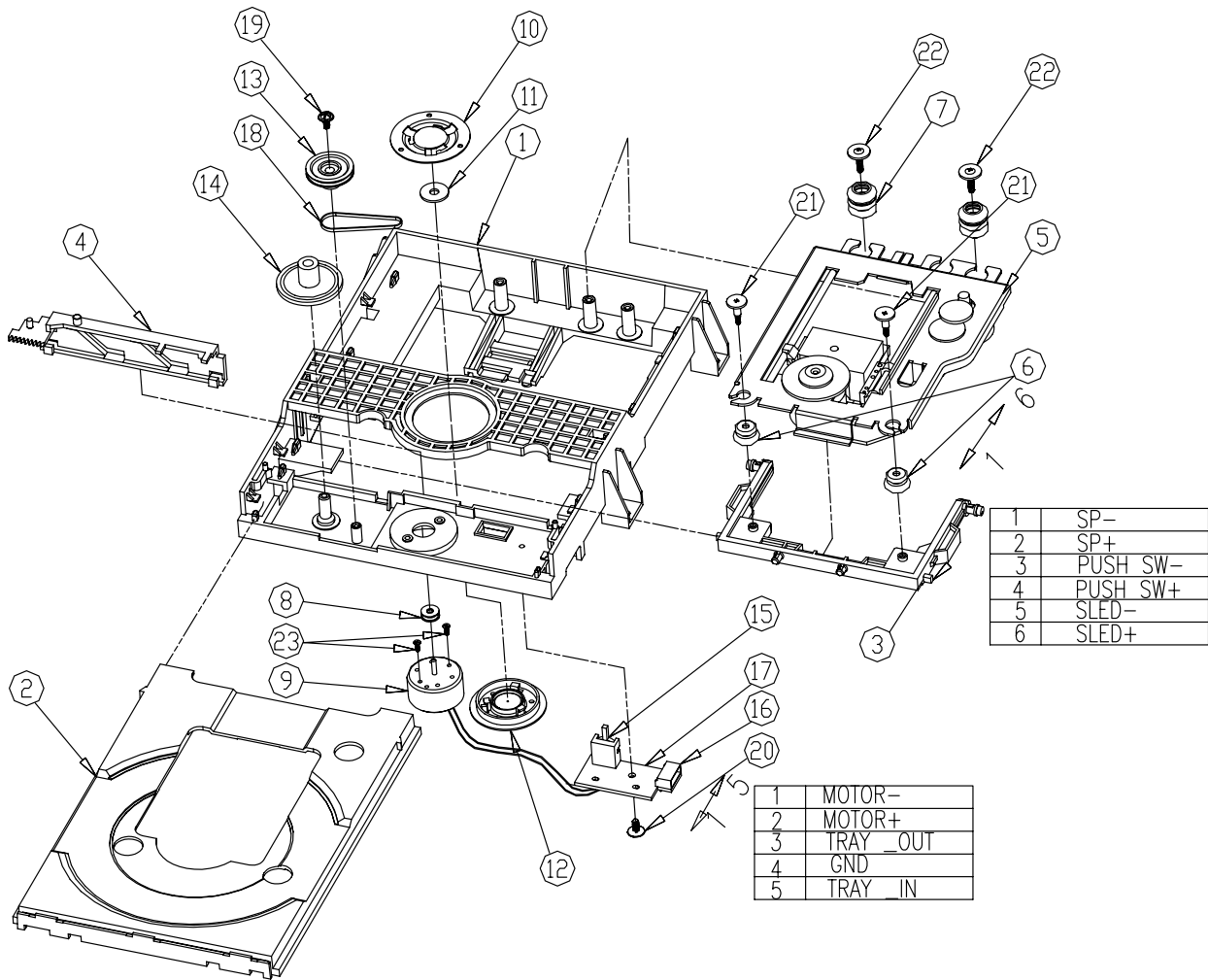

MECHANICAL PART LIST - DVD LOADER

- 1 LOADER BASE
- 2 LOADER TRAY
- 3 FRAME
- 4 CAM
- 5 TRAVERSE
- 6 FRONT DAMPER
- 7 REAR DAMPER
- 8 GEAR-G
- 9 TRAY MOTOR
- 10 CLAMPER TOP
- 11 MAGNET
- 12 CLAMPER DOWN
- 13 GEAR PULLEY
- 14 GEAR-TRAY
- 15 LIMIT SWITCH
- 16 CONNECTOR
- 17 PCB
- 18 BELT
- 19 SCREW FOR GEAR PULLEY
- 20 SCREW FOR PCB
- 21 SCREW FOR FRONT DAMPER
- 22 SCREW FOR REAR DAMPER
- 23 SCREW FOR TRAY MOTOR

SET MECHANICAL EXPLODED VIEW

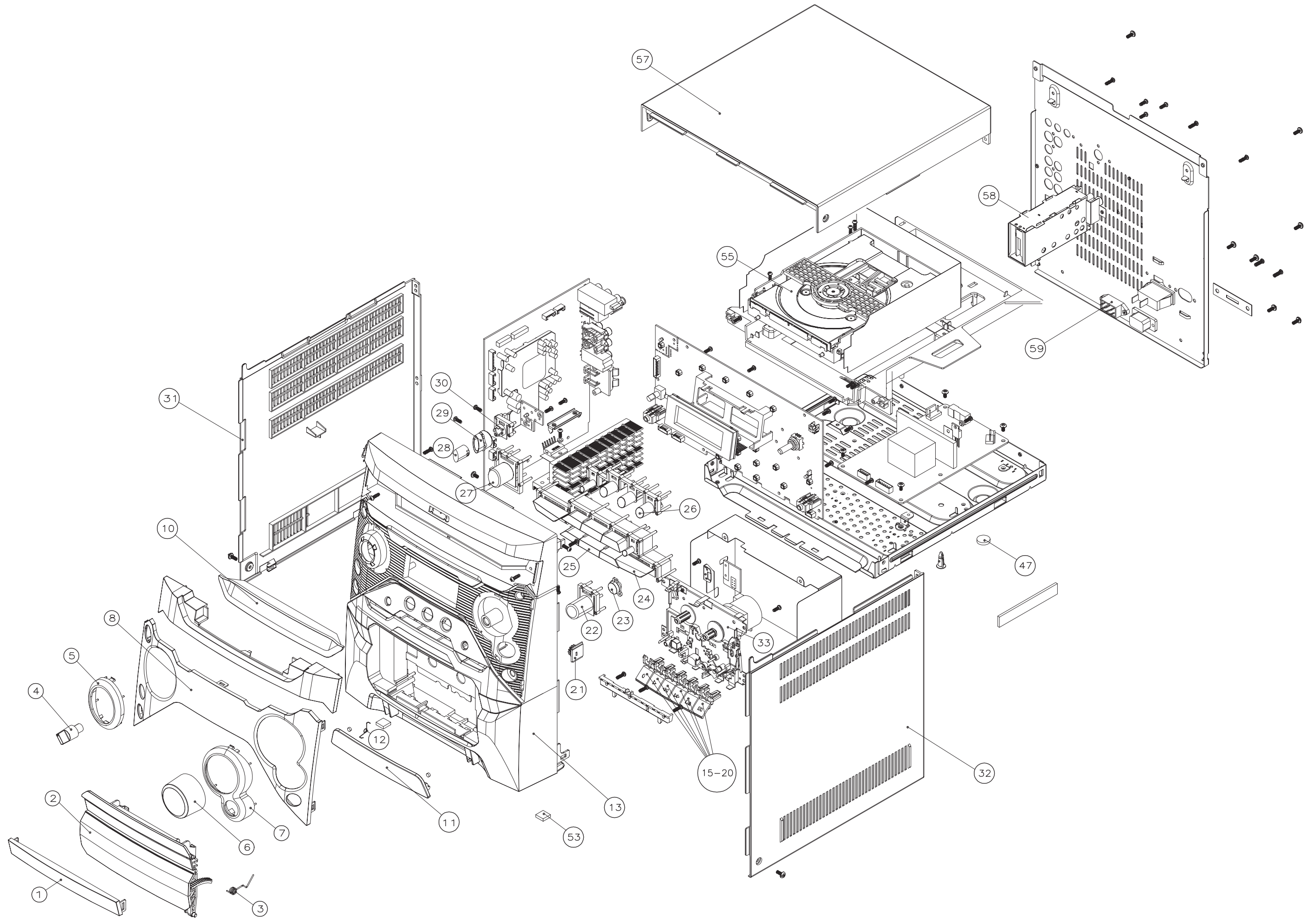

MECHANICAL & ACCESSORIES PARTS LIST

01	9940 000 05296	CASSETTE DOOR LENS	△ 9940 000 01054	LINE CORD 2P 2000MM
02	9940 000 05275	CASSETTE DOOR	9940 000 02731	FM ANTENNA 1500MM
03	9940 000 05307	CASS DOOR SPRING	9940 000 05267	AM LOOP ANT 1300 5TS 2P
04	9940 000 05282	MIC KNOB	9940 000 05268	REMOTE CONTROL 45KEY
05	9940 000 05301	KEY DECORATIVE RING	9965 000 40981	LEFT SPK BOX 30W 4Ω
06	9940 000 05281	VOLUME KNOB	9965 000 40982	RIGHT SPK BOX 30W 4Ω
07	9940 000 05302	VOLUME DECORATIVE RING	9965 000 24676	COND TRIM 3-10PF NP0
08	9940 000 05295	DISPLAY LENS	9965 000 27005	CNTL TRIM 30KΩ
10	9940 000 05274	DVD DOOR	9940 000 00924	RCA CABLE 1500MM
11	9940 000 05276	CASS KEY DOOR	9965 000 23267	RCA CABLE 1200MM OD2.6X5.2
12	9940 000 05306	KEY DOOR SPRING	9965 000 23580	RCA CABLE 1500MM OD2.6MM
13	9940 000 05277	FRONT CABINET		
15	9940 000 05279	CASS KEY RECORD		
16	9940 000 05288	CASS KEY PLAY		
17	9940 000 05291	CASS KEY REWIND		
18	9940 000 05292	CASS KEY F.FORWARD		
19	9940 000 05293	CASS KEY STOP		
20	9940 000 05294	CASS KEY PAUSE		
21	9965 000 22120	DAMPER-ASSY-MODULE-0.8		
22	9940 000 05287	DBB BUTTON		
23	9940 000 05299	DBB LIGHT GUIDE		
24	9940 000 05284	AUDIO KEYS		
25	9940 000 05289	PROGRAM KEYS		
26	9940 000 05285	CONTROL KEYS		
27	9940 000 05286	PLAY BUTTON		
28	9940 000 05283	POWER BUTTON		
29	9940 000 05297	RING POWER LENS		
30	9940 000 05298	POWER BUTTON BASE		
31	9940 000 05304	PANEL LEFT HIPS		
32	9940 000 05303	PANEL RIGHT HIPS		
33	9940 000 05271	CASSETTE DECK ASS'Y		
47	9940 000 05305	RUBBER FOOT D14XT3.0MM		
53	9940 000 01546	FOOT RUBBER		
55	9940 000 05269	DVD LOADER ME M04S-2		
57	9940 000 05273	TOP COVER		
58	9940 000 05309	TUNER BOARD ASS'Y /55/98		
58	9940 000 05714	TUNER BOARD ASS'Y /51		
59	9940 000 01059	SLIDE SWITCH 6P /55/98		

Note: Only these parts mentioned in the list are normal service parts.

REVISION LIST

1.0 Manual 3141 785 31020

Initial Service Manual released.

1.1 Manual 3141 785 31021

In this version, the version /68 and version /79 are added.

P6-11 : Electrical Parts List - Main Board updated

P10-2 : Mechanical Partslist updated